

SYSBEL® **SYSBEL IS SAFETY** **安全·源自西斯贝尔**

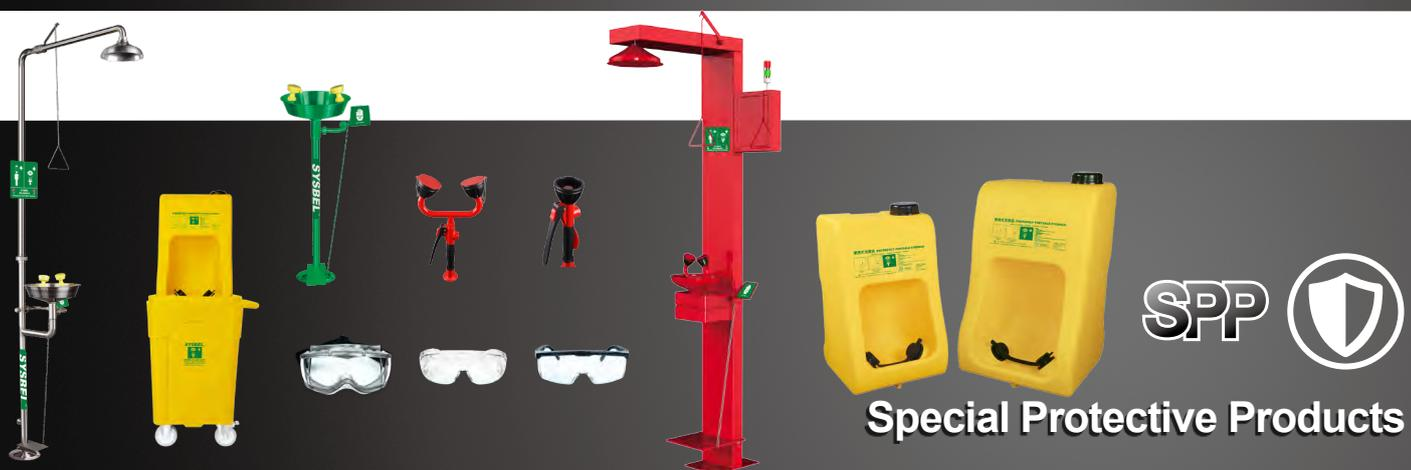

SYSBEL®

SYSBEL IS SAFETY!

SYSBEL is a company who always focuses on environment protection and employee safety and health. **SYSBEL** commits to the exploration and manufacture of world's leading products within Safety Containment Systems (SCS), Spill Prevention, Containment & Control (SPCC) and Special Protective Products (SPP) .

SYSBEL's core value: **SYSBEL IS SAFETY.**

SYSBEL® brand products made by "Shanghai **SYSBEL** Industry & Technology Co., Ltd" are in strict comply with related standards, such as OSHA 29 CFR 1910.106 of American Occupational Safety and Health Administration and NFPA CODE30 of American National Fire Protection Association. **SYSBEL** attaches great importance to product quality management. After strict product testing, its products gain EU "CE" certification and FM Approval, etc. **SYSBEL**, relying on innovative solutions, always maintains the leading position in the industry, and provides quality products and services for the enterprises to ensure occupational safety, reduce fire risks and enhance productivity.

Choose **SYSBEL** You deserve more and better ...

- Safer working environment
- Better occupational protection
- More healthy and efficient working status
- Avoid safety risks; reduce risk loss; lower treatment costs
- Recommended more than 100 products by many customers
- Provide solutions to occupational safety and environment safety
- Ten-year quality guarantee



Contents

Safety Containment Systems **SCS**

Flammable Cabinets	7
Combustible Cabinets	8
Corrosive Cabinets	9
Toxic Cabinets	9
Pesticides Cabinets	10
Waste Liquid Storage Cabinets	10
Emergency Equipment Cabinets	11
Gas Cylinder Storage Cages	11
Safety Storage Cabinets	12
Outdoor Safety Cabinets	13
Mobile Safety Storage Box	13
Waste Recycling Cabinet	14
Explosion-proof Refrigerator	14
Polyethylene Corrosive Cabinets	15
Corrosive Substance Storage Cabinets	16
PP Medicine Storage Cabinets	16
Safety Cans	17
Oily Waste Cans	17
Biohazard Waste Cans	18
Cigarette Butts Receptacle	18
Safety Cabinet Parts	19



Spill Prevention, Containment & Control **SPCC**

Poly Spill Decks	23
Poly Spill Pallets	23
Lab Spill Containment Pallets	23
Splicing Type Poly Spill Decks	24
IBC Poly Spill Pallet	25
Steel Spill Pallets	25
Spill Control Accessories	26
Waterproof Tape	26
Emergency Treatment for Chemical Spills	28
Absorbent Mats	29
Industrial Wipes	30



Universal Absorbent Drip Pan	31
Overpack Salvage Drum & Overpack Spill Kit	32
Wheeled Poly-Overpack Salvage Drum & Mobile Spill Kit	33
Portable Spill Kit	34
Spill Kits in Cart	35
Polyethylene Disposal Bags	35
PVC Float-Type Spill Containment Boom	35



Special Protective Products **SPP**

Combination Unit	40
Drench Hose	41
Wall Mounted Eye/Face Wash	41
Pedestal Mounted Eye/Face Wash	41
Portable Eye Wash Station & Mobile Waste Cart	42
Cable Heating Emergency Shower	43
Emergency Shower Room	43
Wash Sink	43
Wall Mounted First Aid Kit	44
Goggles Products	45
Face Shield	46

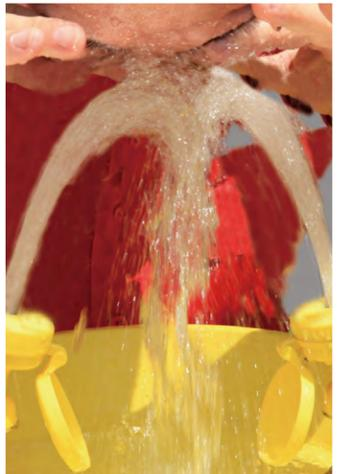

Appendix

Total Solution of Chemical Management in Industry	47
Total Solution of the Chemical Management	48
SYSBEL Safety Cabinet Size Chart	49
SYSBEL Eye Wash Station Selection Guide	50
SYSBEL Absorbent Material Selection Guide	51
User's Guide for SYSBEL Polyethylene Products	52
Regulation Abstract	53
Product Index	54





Safety Containment Systems

One of the Major Causes for fires is improper storage and handling of flammable liquids and chemicals. **SYSBEL** Flammable Liquid Chemical Safety Cabinets, help you to proper store, classify each hazardous chemicals, reduce risks and ensure personal and environmental safety.



Safety Cabinets

Fires instantly destroy everything you have ruthlessly, causing major casualties, property damage and other consequences. What helps to prevent and control fire hazards? Safe storage is a simple measure for avoiding risks. Chemicals classification and grading management is important. **SYSBEL** provides quality Flammable Liquid Safety Cabinets, which will help you to store hazardous chemicals safely and reduce fire risks.

Safety Cabinet of Important Functions

1. Store chemicals safely and reduce fire risks
2. Ensure aid time when fires occur
3. Make dangerous chemicals more recognizable, stored orderly, and properly-stored (isolation, separated or detached storage)
4. Comply with FM Approval Standard for Storage Cabinets (Flammable and Combustible Liquids) Class Number 6050, OSHA 29 CER 1910.106 of American Occupational Safety and Health Administration, NFPA CODE30 of American National Fire Protection Association and Hazardous Chemicals Control Ordinance of State Bureau of Safe Production Supervision and Administration, thus to provide safe storage of flammable liquid and chemicals
5. Improve the availability of chemicals in working place
6. Enhance fire safety through Door-Lock System and fireproof and explosion-proof vent



Types of Chemical Safety Cabinets

In storing chemicals, colors and labels are generally used to identify different chemicals, so if fires occur, it is easy for firemen to identify hazardous chemicals.

Flammable Cabinets	Combustible Cabinets	Corrosive Cabinets	Toxic Cabinets	Pesticides Cabinets	Polyethylene Corrosive Cabinets
Yellow Safety Cabinet for storing flammable liquids (low and median flash point liquid ¹ , flash point < 37.8°C)	Red Safety Cabinet for storing paintings, oil and other flammable liquids (high flash point liquid ² , flash point ≥ 37.8°C)	Blue Safety Cabinet for storing corrosive liquids ³	White Safety Cabinet for storing toxic chemicals	Green Safety Cabinet for storing insecticides, pesticides, disinfectors and other chemicals	Polyethylene Corrosive Cabinet for storing strong polyethylene or corrosive chemicals

[1,2,3] Please refer to List of Hazardous Goods (GB 12268-2012) and List of Hazardous Chemicals of SAWS (State Administration of Work Safety)
¹ OSHA CODE 29 CFR 1910.106 specifies that for Class I and II flammable liquids the cabinet should hold less than 60 Gal. Please learn more of the storage specification on P53.
² Please refer to P49 for types of Safety Cabinets.



SYSBEL® — Flammable Liquid Chemical Safety Cabinets

Prevention is Better than Compensation



FM Certification



TÜV Certification

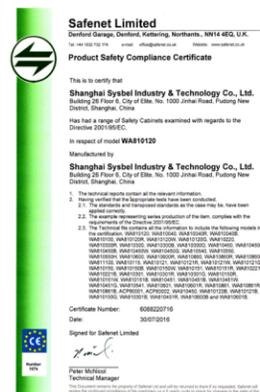

CE Certification



OSHA & NFPA

SYSBEL gets the Approval certificate of various capacities of steel safety cabinet issued by FM Approvals!

Storage security is of great significance!

One of the Major Causes for fires is improper storage and handling of flammable liquids and chemicals. Fire will instantly destroy everything you have ruthlessly. It will cause huge enterprise property loss and security threats to employees, of course, and also induce expensive social cost, time cost...

SYSBEL® brand steel safety cabinets get Approval certificate by FM Approvals. It represents not only the quality of our tireless pursuit of product safety, but also stands for the FM certified product's quality level "best product certified by the highest standards". We hope SYSBEL® brand steel safety cabinets which pass the most rigorous testing, can bring the most reliable protection for your storage and property security.

FM Approvals

FM Approvals Introduction FM is Factory Mutuals abbreviated writing, called: Associated Factory Mutual Fire Insurance Companies. FM was founded in the 18th century, is one of the largest industrial and commercial insurance company in the world, its clients covering 132 countries worldwide. It has more than 100,000 global insurance programs in total. Its order "make property improvements to reduce risk" concept of operations, who is the market leader in today's global property insurance and risk management, loss prevention engineering, with market-leading underwriting capacity and insurance coverage. FM commits to working with customers reduce the risk of a threat to their property through the researches of FM's most advanced property loss prevention, techniques in engineering risk management expertise and comprehensive insurance products, to maintain continued reliability of customer operations. Thus, many of the world renowned manufacturers and commercial customers are becoming customers of FM Global, and also choose to use the FM Approved products to protect their assets.

FM Global offers worldwide industrial and commercial product certification and testing services through FM Approvals. Recognized and respected across the globe, FM Approvals certification assures customers a product or service that has been objectively tested and conforms to the highest national and international standards. FM Approvals is accredited by the U.S. Occupational Safety and Health Administration (OSHA) as a Nationally Recognized Testing Laboratory (NRTL). FM Approvals is also recognized by the American National Standards Institute (ANSI) as a standards development organization (SDO). In addition, FM Approvals is accredited by the International Accreditation Service (IAS).

Products with FM Approvals certification mark means that the product has been tested and comply with specific national and / or international standards and FM Approvals' standards, so that they qualify to launch in a specific region or global marketing. Beyond the product's Diamond FM Approvals certification mark, it conveys the FM idea "Products in engineering and science-based", and the insistence for the FM principle "best product certified by the highest standards", since FM found more than a century. The FM Approved products reliable performance means it can reduce the risk of the customer's assets; and also means that customers can use the product to meet local standards. Since in most cases, FM Approvals' standard is higher and more stringent than local requirements.

TÜV Approvals

Germany's largest product safety and quality certification agency is a recognized inspection agency of the German government. It has a reputation of 145 years in Germany and Europe. As the current leading provider of technical services worldwide, the TÜV Rheinland has a global service network. Since their foundation in 1872, the TÜV Rheinland has been providing safe and sustainable solutions for the challenges arising from the interaction between man, the environment and technology.

For decades, this trademark has won the trust of countless people and enjoyed a high reputation all over the world. It represents that the product has passed the inspection of a neutral institution, and its safety and quality are trustworthy. The TÜV certified products mean that its reliable performance can reduce the risk of customers' assets; meanwhile, it means that the products used by customers can meet the requirements of local standards.



High quality welded steel

Adjustable shelves with anti-leakage design

Shelf bracket welded on both sides of cabinet

Unleaded coating with polish surface, which is corrosion and moisture proof

5.3cm sump to prevent spill

Fireproofing vents to effectively reduce the concentration of volatile substances, and prevent fire hazards. Special spill-proof shelves to avoid chemical leakage by accident.

Double fireproof steel panel and the insulate temperature space between the 2 panel is 38mm

The cabinet has three-point linkage lock, and the door can open 180°

Safety locking devices, double-lock management in line with Hazardous chemicals Control Ordinance.

The label material is made of high quality reflective material to improve the safety of the cabinets in the weak light area



It has acquired FM & CE Certification and is in strict comply with FM Approval Standard for Storage Cabinets (Flammable and Combustible Liquids) Class Number 6050, OSHA 29 CER 1910.106 of American Occupational Safety and Health Administration, NFPA CODE30 of American National Fire Protection Association and Hazardous Chemicals Control Ordinance of State Bureau of Safe Production Supervision and Administration



Adjustable shelves: adjustable among every 6cm floor which can make full use of space



Fireproofing ventilation hole: at both sides of the cabinet, one on the top and the other on the bottom



SYSTEX Three-point linkage lock: make lock safer; Flush paddle handle offers easy operation and save space



SDS management: Standard MSDS file box, the implementation of chemical file management



The three-point bullets: anti-static design structure



Anti-Static Device: conductor grip combine the equipment with the cabinet to conduct the static to earth, thus to prevent fire accident



Self closing device (self-closing door product): comes with self closing system, it can automatically close the metal door under the fuse



Reflective label: In the case of smoke and fire blackouts, the location of the cabinet can be quickly locked by lighting



Thickening packing: The corner support is strengthened and packed in thick box to facilitate transportation and ensure the safety of product transportation

How to choose safety storage cabinets?

Storage Containers

Choose cabinets according to the types and volumes

Confirm the containers are as below: safety cans, oily drums of less than 55Gal, small volume of coating containers, 4L bottles, aerosol containers or smaller bottles. All storage containers must be airtight.



Storage Volume

Confirm the volume of needed safety cabinet

Choose cabinets according to your needed volume. Bigger cabinets offer more storage space. SYSBEL Safety Cabinets have 11 different volumes, namely 4Gal, 12Gal, 22Gal, 30Gal, 45Gal, 54Gal, 55Gal, 60Gal, 90Gal, 110 Gal and 120Gal, you can choose the best type based on storage space and volume.



Service Environment

Ensure the service environment of cabinets

Ensure cabinets are used on horizontal interface, and free from fire sources, dry and ventilated. Choose types based on needs, such as console cabinets, desktop cabinets or cabinets for ventilation hood in the lab, (SYSBEL 10Gal Safety Cabinet) . Also, you can base on leakage prevention demand to install proper PVC tray.



SUMMARY OF GHS PICTOGRAMS



* GHS by United Nations

Special Chemicals Management

For toxic and dangerous chemicals or reagents involved in inspection and testing, industrial and mining, metallurgy, chemical and other industries, it is necessary to use dedicated toxic cabinets for storage, and practice strict security control to ensure safe use of toxic and dangerous chemicals.

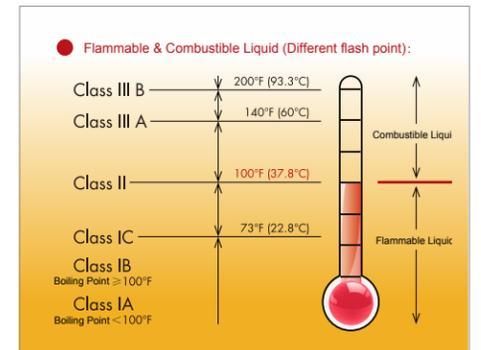
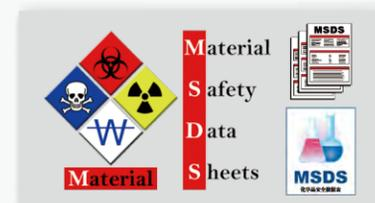

[1]Please refer to List of Hazardous Goods (GB 12268) and List of Hazardous Chemicals of SAWS (State Administration of work safety)
** Please refer to P49 for types of Safety Cabinets

Flammable Cabinets

SYSBEL Flammable Cabinets for storing flammable liquids(low and median flash point liquid, flash point <37.8°C), Reduce the risk of fire, to ensure the safety of life and property.



Volume (Gal/L)	Certification	Door type	Ext dimension (HxWxD/cm)	Packing dimension (HxWxD/cm)	Adjustable Shelves(Pcs)	Shelf Loading Weight(Kgs.)	Model (Manual)	Model (Self-close)	Adjustable Shelf	Remark
4/15	CE	Single	56x43x43	59x50x50	1	50	WA810040	WA810041	WAL040	-
10/38	CE	Single	64x59x60	78x66x67	1	50	WA810100	-	WAL010	-
12/45	FM, CE	Single	89x59x46	103x66x53	1	50	WA810120	WA810121	WAL012	-
12/45	FM, CE	Double	46x109x46	64x116x52.5	-	-	WA3810120	-	WAL03045	EX Piggyback
17/64	FM, CE	Double	61x109x46	75x116x52.5	1	100	WA810170	-	WAL03045	Wall Mounted
17/64	FM, CE	Double	61x109x46	75x116x52.5	1	100	WA3810170	-	WAL03045	EX Piggyback
19/72	FM, CE	Double	91x76x57	105x85x63	1	50	WA0810190	-	WAL019	Undercounter
22/83	FM, CE	Single	165x60x46	179x67x53	3	50	WA810220	WA810221	WAL022	-
23/87	FM, CE	Double	89x89x55	103x96x65	1	50	WA0810230	-	-	Undercounter
30/114	FM, CE	Double	112x109x46	126x116x53	1	100	WA810300	WA810301	WAL03045	-
30/114	CE	Double	112x109x55	126x116x62	1	100	WA810300C	-	-	Comer
45/170	FM, CE	Double	165x109x46	179x116x53	2	100	WA810450	WA810451	WAL03045	-
54/204	FM, CE	Single	165x60x87	179x67x94	3	100	WA810540	WA810541	WAL054	-
60/227	FM, CE	Double	165x86x86	179x93x93	2	100	WA810600	WA810601	WAL060	-
90/340	FM, CE	Double	165x109x86	179x116x93	2	100	WA810860	WA810861	WAL090	-
12/45	GA, CE	Single	89x59x46	103x66x53	1	50	WA810122	-	WAL012	GA Password lock
45/170	GA, CE	Double	165x109x46	179x116x53	2	100	WA810452	-	WAL03045	GA Password lock

Drum Storage Cabinets

SYSBEL drum storage cabinets.Meet the specification of OSHA29CFR 1910.106 and NFPA CODE 30. Form a complete set of slippery course to guide the oil drum bracket cart in and out.



Volume (Gal/L)	Certification	Door type	Ext dimension (HxWxD/cm)	Packing dimension (HxWxD/cm)	Adjustable Shelves(Pcs)	Shelf Loading Weight(Kgs.)	Model	Adjustable Shelf
55/207	CE	Double Door/ Manual	165x86x86	179x93x93	1	100	WA810550	-
110/415	CE	Double Door/ Manual	165x150x86	179x157x95	1	100	WA811100	-
115/434	CE	Double Door/ Manual	165x150x86	179x157x95	2 (Left) 1 (Right)	100	WA810115	WAL115L WAL115R

Combustible Cabinets

SYSBEL Combustible Cabinets for storing paintings, oil and other flammable liquids(high flash point liquid, flash point ≥37.8°C), Suitable for coating, printing, furniture, automobile and other industries.



Volume (Gal/L)	Certification	Door type	Ext dimension (HxWxD/cm)	Packing dimension (HxWxD/cm)	Adjustable Shelves(Pcs)	Shelf Loading Weight(Kgs.)	Model	Adjustable Shelf
4/15	CE	Single Door/Manual	56x43x43	59x50x50	1	50	WA810040R	WAL040
12/45	FM, CE	Single Door/Manual	89x59x46	103x66x53	1	50	WA810120R	WAL012
30/114	FM, CE	Double Door/Manual	112x109x46	126x116x53	1	100	WA810300R	WAL03045
45/170	FM, CE	Double Door/Manual	165x109x46	179x116x53	2	100	WA810450R	WAL03045
60/227	FM, CE	Double Door/Manual	165x86x86	179x93x93	2	100	WA810600R	WAL060
90/340	FM, CE	Double Door/Manual	165x109x86	179x116x93	2	100	WA810860R	WAL090

Corrosive Cabinets

SYSBEL Corrosive Cabinets for storing corrosive liquids, Apply to the LABS of colleges and universities, research institutes, etc.



Volume (Gal/L)	Certification	Door type	Ext dimension (H×W×D/cm)	Packing dimension (H×W×D/cm)	Adjustable Shelves(Pcs)	Shelf Loading Weight(Kgs.)	Model	Adjustable Shelf
4/15	CE	Single Door/Manual	56x43x43	59x50x50	1	50	WA810040B	WAL040
12/45	FM, CE	Single Door/Manual	89x59x46	103x66x53	1	50	WA810120B	WAL012
22/83	FM, CE	Single Door/Manual	165x60x46	179x67x53	3	50	WA810220B	WAL022
30/114	FM, CE	Double Door/Manual	112x109x46	126x116x53	1	100	WA810300B	WAL03045
45/170	FM, CE	Double Door/Manual	165x109x46	179x116x53	2	100	WA810450B	WAL03045
60/227	FM, CE	Double Door/Manual	165x86x86	179x93x93	2	100	WA810600B	WAL060
90/340	FM, CE	Double Door/Manual	165x109x86	179x116x93	2	100	WA810860B	WAL090

Toxic Cabinets

SYSBEL Toxic Cabinets for storing toxic chemicals, Widely used in chemical plants, laboratory in colleges and universities, research institutes, etc.



Volume (Gal/L)	Certification	Door type	Ext dimension (H×W×D/cm)	Packing dimension (H×W×D/cm)	Adjustable Shelves(Pcs)	Shelf Loading Weight(Kgs.)	Model	Adjustable Shelf
12/45	FM, CE	Single Door/Manual	89x59x46	103x66x53	1	50	WA810120W	WAL012
45/170	FM, CE	Double Door/Manual	165x109x46	179x116x53	2	100	WA810450W	WAL03045
12/45	GA, CE	Single Door/Manual	89x59x46	103x66x53	1	50	WA810122W	WAL012
45/170	GA, CE	Double Door/Manual	165x109x46	179x116x53	2	100	WA810452W	WAL03045

Pesticides Cabinets

SYSBEL Safety Cabinets for Pesticides for storing insecticides, pesticides, disinfectors and other chemicals. Suitable for lawn care, golf course, farms, parks, amusement parks and other places.



Volume (Gal/L)	Certification	Door type	Ext dimension (H×W×D/cm)	Packing dimension (H×W×D/cm)	Adjustable Shelves(Pcs)	Shelf Loading Weight(Kgs.)	Model	Adjustable Shelf
12/45	FM, CE	Single Door/Manual	89x59x46	103x66x53	1	50	WA810120G	WAL012
45/170	FM, CE	Double Door/Manual	165x109x46	179x116x53	2	100	WA810450G	WAL03045

Waste Liquid Storage Cabinets

The combination lock waste liquid storage cabinet is based on the design of a standard safety cabinet, which has the same characteristics of fire prevention and ventilation as the safety cabinet;The combination lock safety cabinet is made of anti-corrosion PP board, which is resistant to strong acid,alkali and excellent characteristics with corrosion resistance;The overall design of the PP board is movable, which can be placed in the appropriate compartment according to the user's needs ,to meet the diversified choices of the user;The conventional 6L,10L,20L,and other models of waste liquid barrels on the market can be placed in the cabinet;The combination lock waste liquid storage cabinet adopts electronic combination lock + mechanical lock ,double lock management to improve equipment safety;The use of GA-certified electronic combination locks can effectively achieve the control, safety, anti-theft, and anti-collision of hazardous chemicals, in line with industry standards GA1511-2018.



Volume (Gal/L)	Certification	Door Type	Material	Color	Ext dimension (H×W×D/cm)	Packing dimension (H×W×D/cm)	Adjustable Shelves(Pcs)	Shelf Loading Weight(Kgs)	Model	Adjustable Shelf
30/114	GA, CE	Double Doors/ Manual	18GA High quality steel	Blue	112×109×46	126×116×53	1	50	WA810303	ACP030L
45/170	GA, CE	Double Doors/ Manual	18GA High Quality Steel	Blue	165x109x46	179x116x53	2	50	WA810453	ACP030L

Emergency Equipment Cabinets

It is mainly used for the storage of personal protective equipments or emergency equipments, such as helmets, protective glasses, overalls, protective masks, safety shoes, safety locks, first aid kits, so it is also known as PPE cabinet. In addition, emergency equipment cabinet is also widely used to store absorbents, chemical suits, chemical boots, protective glasses, protective goggles and other emergency equipments.



WA920450 WA930450 WA920450Y WA930450Y

Emergency Equipment Cabinet (PPE Cabinet)							
Color	Details	Volume (Gal/L)	Certification	Ext dimension (H×W×D/cm)	Packing dimension (H×W×D/cm)	Adjustable Shelves (Pcs)	Model
Gray	With the Windows	45/170	CE	180X90X45	192X96X52	3	WA920450
Gray	Without Windows	45/170	CE	180X90X45	192X96X52	3	WA930450
Yellow	With the Windows	45/170	CE	180X90X45	192X96X52	3	WA920450Y
Yellow	Without Windows	45/170	CE	180X90X45	192X96X52	3	WA930450Y

Gas Cylinder Storage Cages

SYSBEL offers a comprehensive range of Gas Cylinder Storage Cages, which are available in horizontal, vertical and horizontal & vertical styles to hold LPGs and gas cylinders. Whether it is for storing LPGs, Gas Cylinders or a mixture, we have a solution for you. These rugged gas cylinder storage cages protect from theft and unauthorized access. They securely and efficiently store cylinders in industrial or commercial outdoor or indoor with highly visible ammables signs. And meet NFPA 58 for LPG storage and OSHA 1910.110 regulations.



WA710204 WA710208 WA710309 WA710216 WA710318

Gas Cylinder Storage Cages							
Cylinder Type	Certification	Position	Capacities	Racks	Product Size (H×W×D/cm)	Packing Size (L×W×H/cm)	Model
LPG	CE	Horizontal	4	1	96x76x76	98x80x25	WA710204
			8	3	180x76x76	190x80x25	WA710208
			16	6	180x152x76	190x160x45	WA710216
Compressed Gas	CE	Vertical	9	-	180x76x76	190x80x25	WA710309
			18	-	180x152x76	190x160x45	WA710318
LPG & Compressed Gas	CE	8 horizontal and 9 vertical cylinder		3	180x152x76	190x160x45	WA710589

Safety Storage Cabinets

- The cabinet is made of high-strength steel plate. The surface of the cabinet body is electrostatically sprayed with orange-stripe molding powder, which is easy to clean, scratch-resistant, impact-resistant and durable. Multi-layer fireproof gypsum board insulation is used in the cabinet compartment to achieve the purpose of fire prevention.
- In normal use, the semi-automatic door can be manually opened or closed; if a fire occurs, the temperature reaches 122°F (50°C), the built-in fuse connection system works, and the opening door will be automatically closed to protect the storage of items in the cabinet. The cabinet door has a damping screw to adjust the size of the door force of the switch.
- The baffle plate of ventilation holes automatically close at 158°F (70°C) in a fire environment. The ventilation system can be connected with an exhaust pipe or a circulating air filter.
- When fire occurs, the special heat-sensitive materials provided in the door joints and all joints will automatically expand and fill the gaps to ensure that the interior of the cabinet is sealed.
- Each door has a separate cylindrical lock to effectively prevent unauthorized use. The door is affixed with reflective warning labels in multiple languages. In the event of fire or power failure, it is very conspicuous under the flashlight.
- The detachable bottom leakage groove is equipped with guide plate on the three sides, which is used together with the perforated inserts to effectively catch the liquid overflowing from the shelf. The container is placed on the perforated inserts to avoid being soaked in the bottom leaking groove.
- It is configured 3 standard adjustable steel laminates, with an adjustable spacing of 32mm for each intervals, the load capacity of the laminate is 75KG. The turn-up height of the laminate is 30mm, which prevents the small container from accidentally slipping off.
- The bottom of the cabinet is provided with adjustable leveling feet, which can balance the cabinet even on uneven surfaces.
- It is equipped with electrostatic grounding conductive port to facilitate the connection of static grounding conductors.
- The safety cabinet complies with EN 14470-1 and complies with NFPA 30 and OSHA regulations. Among them, SE830450 passed TÜV independent fire test and obtained TÜV certification.

TÜV Certification



SE830450

EN14470-1, NFPA30 & OSHA Standard



SE830230 SE490190 SE490230 SE490300 SE490450

Safety Storage Cabinets												
Fire resistance (min)	Door Type	Color	Certification	Ext dimension (H×W×D/cm)	Int dimension (H×W×D/cm)	Standard adjustable laminate (block)	Load bearing of laminate (Kg)	Leakage tank capacity at the bottom (L)	Outlet connection diameter (mm)	Store a single largest container(L)	Volume (Gal/L)	Model
30	Single Door/Self-close	Yellow	CE	204×60×62.5	218×67×74	3	75	18.5	100	10	23/87	SE830230
30	Double Door/Self-close	Yellow	TÜV	204×116×62.5	218×123×74	3	75	37	100	17	45/170	SE830450
90	Double Door/Self-close	Yellow	CE	63×110×59	77×117×70.5	-	-	32	75	7.5	19/72	SE490190
90	Single Door/Self-close	Yellow	CE	204×60×62.5	218×67×74	3	75	18.5	100	9	23/87	SE490230
90	Double Door/Self-close	Yellow	CE	204×90×62.5	218×97×74	3	75	30	100	12	30/114	SE490300
90	Double Door/Self-close	Yellow	CE	204×116×62.5	218×123×74	3	75	37	100	17	45/170	SE490450

*Selection tips: The colors of this series of products are yellow, blue, white, etc. Only the colors of the cabinet doors are different. The yellow series SKU is shown in the pictures above. For the blue series, please add "-B" after the SKU in the table above. White series Please add "-W" after the SKU in the table above.

Outdoor Safety Cabinets

1. With weatherproof structure design, the cabinet can be placed outdoors, providing a convenient and safe storage solution for flammable and combustible substances.
2. The special door lock protective cover can effectively prevent rain and dust from corroding the lock. Coated with outdoor resin powder on the surface of the cabinet, it is also resistant to UV and rain corrosion.
3. The forklift slot on the bottom of the cabinet makes it easy to transport.
4. In order to effectively ensure the stability of the cabinet in bad weather, the cabinet can be fixed on the ground well with four stainless steel expansion bolts at the four corners.



Outdoor Safety Cabinets								
Volume (Gal/L)	Certification	Color	Door type	Ext dimension (H×W×D/cm)	Packing dimension (H×W×D/cm)	Adjustable Shelves(Pcs)	Shelf Loading Weight(Kgs.)	Model
45/170	CE	Gray	Double Door/Manual	180×109×57	194×116×63	2	100	WA510024
115/434	CE	Gray	Double Door/Manual	180×150×98.5	194×157×106	2	100	WA510025

* The colour yellow is optional.
 * WA510025 is compatible with rollers of WADR001 for storage of oil and chemical barrels.

Mobile Safety Storage Box

A large number of production tools are needed on production sites or in factories, such as large electric welding machines, pipe wrench, hammers and other tools. Smaller tools such as adjustable wrench, spanner, screwdriver, etc. The disorder of these tools caused by the negligence of production workers may results in relatively messy at the construction site. In addition to this, the flow of personnel at the construction site or other construction situation is relatively large, which may lead to the problem of safe storage of tools.



Mobile safety storage box				
Certification	Colour	Ext dimension (H×W×D/cm)	Packing dimension (H×W×D/cm)	Model
CE	Yellow	69.9×121.9×61	72×125×64	WA940101
CE	Yellow	85×121.9×76.4	87.5×125×79	WA940102

Caster (optional)

In the absence of track tools such as forklifts, casters can be equipped to move the carriage of truck. The basic dimensions of casters are as follows:

Product	Material	Installation height(cm)	Baseplate size (cm)	Installation pitch-row(cm)	Aperture (mm)	Bearing (kg)	Remarks
Caster	Polyurethane	16.5	11.5*10	7.2*8.5	8.5	350	Equipped with 16 sets of M8X12 bolts and M8 locknuts

Equipped with four casters, two of them are universal wheels for brake, the other two caster are directional wheels. It's easy to be fixed after moving. The total bearing is 0.9 tons.



Waste Recycling Cabinet

The main body of this product is a recycling cabinet. The front of the cabinet includes the delivery port and the cabinet door. The cabinet has a garbage bag fixing rack and a bag ring fixing ring. At the same time, there is a set of inductive antivirus equipment in the cabinet, including sensors, ultraviolet disinfection lamps and logic control unit.



Waste Recycling Cabinet							
Volume (Gal/L)	Door Type	Material	Color	Ext dimension (H×W×D/cm)	Packing dimension (H×W×D/cm)	Power Supply (V)	Model
12/45	Single Door/Manual	1.0mm galvanized steel	Yellow	80×40×35	94×47×43	220	WA8109400

Explosion-proof Refrigerator

For the storage of flammable, explosive, easy to evaporate, corrosion and other chemical reagents, laboratory reagents and so on. Applicable to colleges and universities, laboratories, research institutes and other experimental sites.



Explosion-proof Refrigerator									
Voltage	Power	Ext dimension (H×W×D/cm)	Packing dimension (H×W×D/cm)	Volume (L)	Type of Ex-proof	Ex-proof Grade	Number of Shelf	G.W. (Kgs.)	Model
220V/50Hz	140W	83.5x59.7x63.5	63x51.5x41.5	118	ATEX(Ex-proof Inside)	II3GEx II T6	2/1	49	LSEF001118
220V/50Hz	210W	184x60.5x59.8	129x56x50	310	ATEX(Ex-proof Inside)	II3GEx II T6	4	77	LSEF002310

Polyethylene Corrosive Cabinets

One-piece construction forming polyethylene corrosive cabinet provide maximum safety storage protection for storing harsh acids or corrosive chemicals

SYSBEL Polyethylene corrosive cabinet, with seamless structure, ensure almost no leakage, and excellent performance of corrosion resistance and secondary leakage prevention and control. Double padlocks help to achieve

double-person lock management, which is in line with EPA264.175 of the U.S. EPA, OSHA29CFR1910.1450 of the U.S. OSHA and Chinese Management of Hazardous Chemicals Ordinance (December 1, 2011 edition). On the cabinet doors, there are acidic and corrosive chemical warning labels to give your chemical storage management double guarantee.

Countertop Single Door Polyethylene Corrosive Cabinet ACP80001

4 Gal storage capacity; all-plastic and no-stopper design, excellent corrosion resistance; the cabinet shelf can be removed according to needs to improve space utilization; both sides of door can be hinged and door can be opened on both sides, to fully use table space; on both sides of cabinet, there are two vents, can open the lid for ventilation or discharge of pressure gas when necessary; double padlock design to meet the requirements for double-person lock management. The product is CE certified.

Undercounter Double Door Polyethylene Corrosive Cabinet ACP80002

22 Gal storage capacity; all-plastic and no magnetic door holder design, excellent corrosion resistance; cabinet shelves can be removed according to needs to improve space utilization; on both sides of cabinet, there are two vents, can open the lid for ventilation or discharge of pressure gas when necessary; double padlock design to meet the requirements for double-person lock management. The product is CE certified.

Polyethylene Corrosive Cabinets

Volume (Gal/L)	Number of Doors and Style	Ext dimension (H×W×D/cm)	Packing dimension (H×W×D/cm)	Adjustable Shelves (Pcs)	Volume of Bottom Leakage(Gal/L)	Shelf Loading Weight(Kg/s)	G.W. (Kgs.)	Model
4/15	One/Desktop	49x41x36	53x43.5x42	1	1.79/6.8	20	8.8	ACP80001
22/83	Two/Undercounter	89x90.5x54.4	91.5x93x66.5	4	3.17/12	20	35.5	ACP80002



ACP80001



ACP80002

Color Classification	Internal dimensions H×W×D(cm)	Cabinet Bottom to Ground/cm	Shelf Effective Width/cm	Shelf Effective Depth/cm	Bottom Sump Effective Width/cm	Bottom Sump Effective Depth/cm	Shelf Hook Qty	Minimum Distance from First Shelf to the Top/cm	Minimum Distance from First Shelf to Second Shelf/cm	Minimum Distance from Last Shelf to Bottom Sump/cm	Models
Blue	44x39.5x30.5	2.3	26.4 (L1)	35.6 (D1)	37 (L2)	26 (D2)	1	16 (H1)	—	25.5 (H3)	ACP80001
Blue	76x89x49.5	6.5	37.7 (L3)	43.6 (D3)	47.2 (L4)	43.5 (D4)	2	17.5 (H1)	22.5 (H2)	26 (H3)	ACP80002

Remarks:
 Cabinet top platform effective size: 36.4x27.2 (ACP80001,LxW/cm) 83.3x46.7 (ACP80002,LxW/cm)
 Shelf effective size: 26.4x35.6 (ACP80001,L1xD1/cm) 37.7x43.6 (ACP80002,L3xD3/cm)
 Bottom sump effective size: 37x26 (ACP80001,L2xD2/cm) 47.2x43.5 (ACP80002,L4xD4/cm)

* Tips: When strong corrosive chemicals in the storage cabinets leak, the leaked chemical liquids will flow to the sump at the bottom of cabinets. Please use adsorbents and other spill control products to remove spills timely under the guidance of professionals.

[1] Please refer to List of Hazardous Goods (GB 12268-90) and List of Hazardous Chemicals of SAWS (OSHA Code 29CFR 1910.106 2002 edition).

** Please refer to P35 and P37 for types of Safety Cabinets.



It is CE approved, in line with EPA264.175 of EPA and OSHA29CFR1910.1450 of OSHA as well as Hazardous Chemicals Control Ordinance of SAWS.



Double padlock to achieve double-person lock management, to provide a higher level of security (padlock is on optional part)



Special design of cabinet top, which can also be used as a worktable



Two vents on both sides of the cabinet, with removable lids for ventilation or discharge of pressure gas when necessary



Cabinet shelves can be removed to enhance space utilization

Corrosive Substance Storage Cabinets

1. Constructed of 8mm polypropylene(PP) panels, offering superior protection against harsh acid, alkali and corrosion.
2. Adjustable and reversible shelves meet diverse choices of users.
3. Formed with bent plates to make it stable and prevent from being out of shape.
4. Divided into two parts to store different chemicals, making good use of storage space.
5. Provided with independent vents which can be connected with exhaust systems.
6. Door hasp accepts padlock to achieve double locks for security against unauthorized use.



ACP810004 ACP810012 ACP810024 ACP810030 ACP810048 ACP810048T

Corrosive Substance Storage Cabinets

Volume (Gal)	Certification	Door type	Material	Color	Ext dimension (H×W×D/cm)	Packing dimension (H×W×D/cm)	Adjustable Shelves	Model
4	CE	Singal Door	8mmPP(Polypropylene)	white	59x46x43	62x48x48	1	ACP810004
12	CE	Singal Door	8mmPP(Polypropylene)	white	89x59x46	91.5x61x49	1	ACP810012
24	CE	Double Door	8mmPP(Polypropylene)	white	89x90.5x58	102x92x57	1	ACP810024
30	CE	Double Door	8mmPP(Polypropylene)	white	112x109x46	125x116x52.5	1	ACP810030
48	CE	Four Door	8mmPP(Polypropylene)	white	180x109x46	193x116x53	2	ACP810048
48	CE	Four Door	8mmPP(Polypropylene)	white	180x109x46	193x116x53	2	ACP810048T

PP Medicine Storage Cabinets

The 4-door Medicine storage cabinet produced by SYSBEL is made of 8mm thick corrosion-resistant PP plate. The cabinet structure is stable and durable, and it is used to store various medicines and most corrosive chemicals. PP medicine cabinets can be standardized, organized, and classified to store chemicals of different natures and hazard levels, effectively preventing and reducing the risk of human or natural disasters.



ACP810045B



ACP810045A

PP Medicine Storage Cabinets

Certification	Door Type	Material	Color	Product Size (H×W×D/cm)	Packing Size (H×W×D/cm)	Stander Accessory	Model
CE	2	8mm thick PP board	White	180x90x45	193x92x52	4 adjustable shelf, 1 fixed shelf, tempered glass window	ACP810045A
CE	4	8mm thick PP board	White	180x90x45	193x92x52	3 adjustable shelf, tempered glass window	ACP810045B

Safety Cans

Type-I metal safety cans are storage containers which can be used to fill or dump liquid through the same bottleneck. With unique handle and clamp design, one force can open the can, which is easy to dump and carry. All models of security cans are equipped with a flame-arresting mesh which effectively removes heat and prevents flashback. The safety cans automatically close to prevent overflow and leakage effectively. The automatic pressure relieving system can relieve pressure when the pressure is within 0.2 to 0.35 kg / sq cm (3 to 5 pounds / square inch) to avoid accidental eruptions or explosion hazards.



Safety Cans							
Capacity (Gal/L)	Certification	Ext. Dimensions (HxD/cm)	Packing Dimensions (HxWxD/cm)	Red Model TYPE I	Yellow Model TYPE I	Red Model TYPE II	Yellow Model TYPE II
2.5/9.5	CE	26x29	29x32x32	SCAN001R	SCAN001Y	SCAN003R	SCAN003Y
5/19	CE	40x29	43x32x32	SCAN002R	SCAN002Y	SCAN004R	SCAN004Y

Oily Waste Cans

A good helper for you to collect oily trashes!

In order to prevent fire risks and collect rags and cloth submersed in oil (flammable solvents, linseed oil and other flammable liquids), please use OSHA standard oily waste can. **SYSBEL** oily waste can has special lid whose opening angle is no more than 60 degree. The self-closing lid design ensures the can tightly closed in the absence of external force, to effectively control the three elements of fires*.



Oily Waste Can Dolly

Heat (or ignition source): mechanical electrostatic line damaged, a lighted match or sparked cigarettes, etc
 Oxygen: oxygen in the air
 Fuel: flammable and combustible liquids, such as diesel kerosene, gasoline, etc

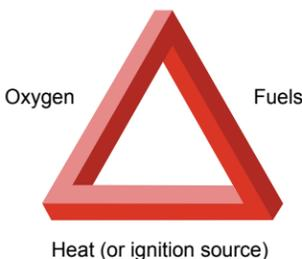

Oily Waste Cans						
Capacity (Gal/L)	Ext. Dimensions (HxD/cm)	Packing Dimensions (HxWxD/cm)	Steel Dolly for Oily Waste Cans		Red Model	Yellow Model
			Dolly Model	Ext. Dimension (DxH cm)		
6/22.6	40x30	46x42x42	WAS006	32x8	WA8109100	WA8109100Y
10/38	46x35	52x47x47	WAS0010	37x8	WA8109300	WA8109300Y
14/52.9	51x41	57x51x51	WAS0014	43x8	WA8109500	WA8109500Y
21/79.3	60x47	63x56x56	WAS0021	49x8	WA8109700	WA8109700Y

Biohazard Waste Cans

- Constructed of polyethylene (PE), which are resistant to most chemical compounds.
- One-piece, blow-molded construction has no seams to develop leaks.
- Self-closing lid stays closed when not in use.
- Convex lugs moves easily from workstation to workstation.
- Foot lever opens lid to 60 degrees(max.) for hands-free access.
- Labeled for easy identification.
- Comply with OSHA 29 CFR 1910.125 and UL.
- Used to store most hazardous solid waste.
- With or without hazmat bags is permitted.
- Some of the chemicals that are not compatible with polyethylene are strictly forbidden, please refer to their Material Safety Data Sheet (MSDS).
- Grasp the lugs with both hands and keep level for carrying.
- Recommended to choose SYSBEL oily waste can for combustible waste storage.
- Loading on lid is prohibited;



Biohazard Waste Cans						
Material	Capacity (Gal/L)	Certification	Diameter(cm)	Packing Dimension (H*W*D/cm)	Red Model	Yellow Model
PE	6/22.7	CE	φ300	42x38x38	WA8109200	WA8109200Y
PE	14/53	CE	φ380	50x53x48	WA8109600	WA8109600Y

Cigarette Butts Receptacle

Made of polyethylene with UV inhibitor and flame-retardant. Long poly tube design restricts oxygen and extinguish burning butts rapidly. Umbrella-shaped covered head keeps water out eliminates heat. Stainless steel connectors which tightly connect the receptacle have rust and corrosion resistance. Included steel pail that collects thousands of unsightly butt. Anti-theft design prevents theft or vandalism padlock is not provided.



Cigarette Butts Receptacle				
Capacity (Gal/L)	Ext. Dimensions (HxWxD/cm)	Packing Dimensions (HxWxD/cm)	Red Model	Gray Model
2/8	89.5x34.5x34.5	91x35.5x35.5	CBR8101	CBR8102

Safety Cabinet Parts

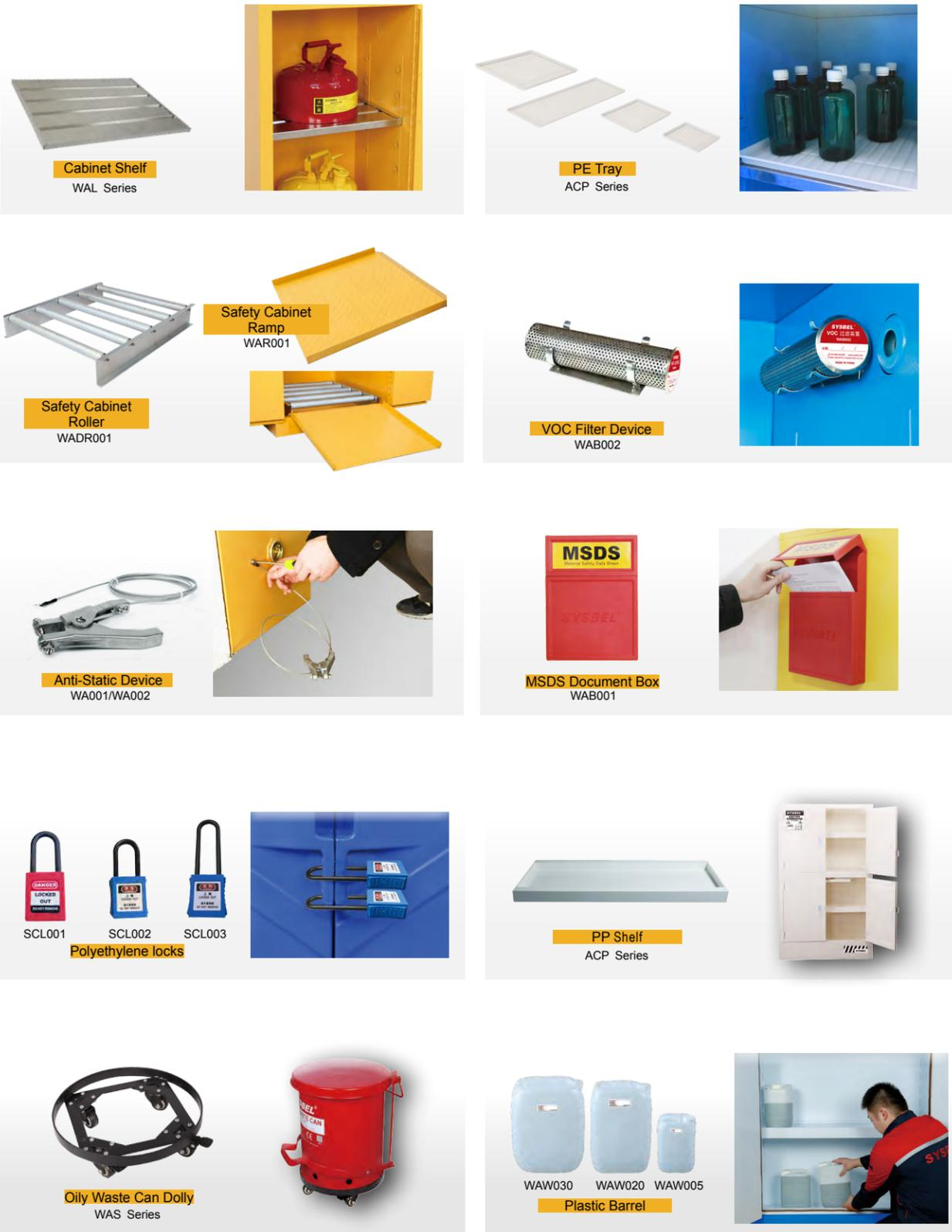

Safety Cabinet Parts

Type	Name of part	For the type of Cabinet	Ext. Dimensions (H×W×D/cm)	Model	Functions
Shelf	Galvanized Steel Shelf	4 Gal	2.7x34x33	WAL040	More storage area divisions for diversified needs
	Galvanized Steel Shelf	10 Gal	2.7x50x50	WAL010	
	Galvanized Steel Shelf	12 Gal	2.7x50x36	WAL012	
	Galvanized Steel Shelf	19 Gal	2.7x67x45	WAL019	
	Galvanized Steel Shelf	22 Gal	2.7x51x36	WAL022	
	Galvanized Steel Shelf	30/45 Gal	2.7x100x36	WAL03045	
	Galvanized Steel Shelf	54 Gal	2.7x77x51	WAL054	
	Galvanized Steel Shelf	60 Gal	2.7x77x76	WAL060	
	Galvanized Steel Shelf	90 Gal	2.7x100x76	WAL090	
	Galvanized Steel Shelf	110 Gal	2.7x141x36	WAL110	
	Galvanized Steel Shelf	115 Gal	2.7x70x76 (Left) 2.7x70x36 (Right)	WAL115L WAL115R	
Filter Device	VOC Filter Device	Steel Safety Cabinets	225*65*70 Diameter 55	WAB002	Reduce VOC concentration inside the cabinet.
Cabinet Roller	Oily Drum Safety Cabinets Roller	55/110/115 Gal	11.5x75x68	WADR001	Supporting storage for oily and chemical drums
Cabinet Ramp	Oily Drum Safety Cabinets Ramp	55/110/115 Gal	3.5x68x58	WAR001	Special tread design to increase friction, convenient for oily drum cart loading and unloading operations
Ground Connection	Antistatic Device	Steel Safety Cabinets	Φ2mm, Length 1.5m	WA001	Promptly eliminate electrostatic charges, to prevent static sparks
	Antistatic Device	Steel Safety Cabinets	Φ2mm, Length 2m	WA002	
Document Box	MSDS Document Box	Steel Safety Cabinets	30.8x23x4.5	WAB001	Important documents data storage
Locks	Metal Locks	Metal Safety Cabinets	The lock rod DI 4mm	SCL001	Apply to double lock management
	Polyethylene locks	PP Safety Cabinets, Short	Inner Chain height 38mm	SCL002	
	Polyethylene locks	PP Safety Cabinets, Long	Inner Chain height 76mm	SCL003	
Ventilation Parts	Cabinet Ventilation Parts	Metal Safety Cabinets	"2"external thread, DN50	WA005	For external ventilation
	PP Cabinet Ventilation Parts	PP Safety Cabinets	"1.5"external thread, DN50	WA006	
Shelf	PE Shelf	4 Gal, ACP80001	3x38.8x30	ACPL001	Different storage area divisions for diversified needs.
	PE Shelf	22 Gal, ACP80002	3x48x43	ACPL002	
	PP Shelf	4 Gal, ACP80004	6x43.3x35.8	ACPL004	
	PP Shelf	12Gal, ACP80012	6x56.3x38.8	ACPL012	
	PP Shelf	24Gal, ACP80024	6x87.8x47.8	ACPL024	
	PP Shelf	30/48Gal, ACP80030 ACP80040	6x106.5x38.7	ACPL048	
Can Dolly	Oily Waste Can Dolly	14G Oily Waste Cans	8x43x43	WAS0014	Supporting and moving Oily Waste Cans easily
	Oily Waste Can Dolly	21G Oily Waste Cans	8x49x49	WAS0021	
Plastic Barrel	Plastic Barrel	Plastic Barrel (5L)	25.5x16x18	WAW005	More sizes to meet diversified needs
		Plastic Barrel (20L)	41.5x29x22	WAW020	
		Plastic Barrel (30L)	43x32x29	WAW030	

PE plastic tray

Product specification	wall thickness	material	color	shape dimension(H×W×D/cm)	model	description
4 gallons cabinet PE plastic tray	2.2mm	PE	Milky white	34x33x2.2	WAT004	Place in cabinet to contain weak corrosive chemicals
12/22 gallons cabinet PE plastic tray	2.2mm	PE	Milky white	50x36x2.2	WAT01222	
30/45/90gallons cabinet PE plastic tray	2.2mm	PE	Milky white	100x36x2.2	WAT03045	
60 gallons cabinet PE plastic tray	2.2mm	PE	Milky white	76.4x76x2.2	WAT060	

Standard configuration	For weak corrosive liquid flameproof (blue metallic) cabinet only as standard
Optional configuration	Optional for other cabinets



Spill Prevention, Containment & Control

Spill and leakage risks are major sources of hidden danger in the workplace. **SYSBEL** Spill Prevention, Containment & Control series, help you to keep the storage environment of oily and chemical drums clean, to effectively prevent and control possible liquid splashes, spills or pollution of spilled liquids. We also provide more emergency treatment products, to solve problems in a timely manner and cope with accidents with ease.



Chemical Spill Prevention and Control

- Thicker side border and central load-bearing structure are very strong, which can firmly carry fully-loaded oil drums, chemical barrels and other storage containers and equipment.
- HDPE material, anti-UV, anti-rust, anti-corrosion, suitable for most chemicals.
- Anti-skid gratings, which will not rupture at full load, are removable and easy for rapid treatment of liquid spill.
- The spill pallet can use forklift, while the spill deck can be assembled to form a spill control workstation.
- Keep the floor dry to avoid slip and fall.
- All spill pallets and decks are stackable, to save space and transport costs.
- Comply with the regulations of EPA 40 CFR 264.175 of the U.S. Environmental Protection Agency (EPA) and the regulations of Spill Prevention and Control Act (SPCC) as well as U.S. NPDES.



2-drum spill pallets with stackable structure save space and transportation costs



Hexagonal drain plug facilitates drainage



2-drum and 4-drum spill pallets with stackable structure save space and transportation costs



2-drum and 4-drum spill pallets have forklift slots for convenient forklift operation to improve efficiency (*forklift overload prohibited)



Hydraulic carrying vehicles can also be used to move pallets, which is more convenient



Poly spill pallet ramps make it easier to move large articles

SPCC Spill Prevention, Containment & Controls

Poly Spill Decks

The poly spill deck is lower than the pallet, thus saving the space, improving the safety, efficiency and facilitating handling of oil drums and chemical drums. Generally, the poly spill deck is used for storing oil drums, chemical drums, etc., instead of transferring such containers. When installed in a workshop, the spill deck can be used for various operations (oil extracting, filling and separating, etc.), as a platform. It is also equipped with the same grate and drain holes. Various decks can be assembled to form a stable and reliable workstation.



Poly Spill Decks						
Type	200L Drum Quantity	Capacity (Gal/L)	Loading Capacity (Kgs.)	Ext. Dimensions (HxLxW/cm)	Forklift Operation	Model
Single Drum	1	11/42	600	15x68x68	NA	SPP401
2 Drum	2	21/80	1500	15x130x66	NA	SPP101
4 Drum	4	40/150	2500	15x130x128	NA	SPP103

Poly Spill Pallets

The poly spill pallet is actually a spill-proof plastic pallet with sump and forklift groove. It can be used for storing, handling and transferring oil drums and chemical drums. All liquid leaking out will flow into the sump rather than the ground. With the supporting ramp, chemical drums can be handled easily and quickly. The high-strength mobile and removable grate is easy to remove, clean and replace. Liquid in the sump can be discharged through the leakage holes, and most of liquid can be recycled. New upgraded 4-Drum pallet is equipped with forklift trucks with a width of 550 mm and 650 mm on the vertical side. Fork groove, to facilitate customer operations. The pallet is surrounded by a stacking limit. Multiple pallets can be accurately stacked and packed for transportation, which is convenient for forklift truck transshipment and maximizes the transportation efficiency. Save space and transport costs.



Poly Spill Pallets						
Type	200L Drum Quantity	Capacity (Gal/L)	Loading Capacity (Kgs.)	Ext. Dimensions (HxLxW/cm)	Forklift Operation	Model
2 Drum	2	32/120	1500	30x130x66	Bidirectional operation	SPP102
2 Drum	2	58/220	2000	45x131x67	Bidirectional operation	SPP102H
4 Drum	4	70/265	3000	30x132x131	Quadridirectional operation	SPP104-2

Lab Spill Containment Pallets

1. Modeled-in sump catches leaks, drips and spills to keep your storage areas clean and safe and is 100% tested leaktight.
2. Constructed of durable Propenepolymer material to resist UV rays, rust, corrosion and most chemicals.
3. Used as a console to prevent the experimental table from pollution.
4. Regarded as a secondary container to hold corrosive chemicals and placed in a standard safety cabinet for storing and transferring in batch.
5. Set under the experimental console to increase the leakage volume for protecting and easily cleaning.
6. Equipped with holes on decks, making it can be used as a tube rack for fear of glass equipment damaging by misoperation.
7. Modular deck components can be mixed and matched to fit the space.
8. Also be considered as a secondary storage container without grate.
9. Translucent white sidewalls allow easy visual inspection.
10. Comply with EPA 40 CFR 264.175 and NPDES.



Lab Spill Containment Pallets						
Material	Feature	Loading Capacity (Kgs.)	Product Size (H*W*D/cm)	Packing Size (H*W*D/cm)	Sump Capacity (L/Gal)	Model
PP	Leak-proof and corrosion-resistant laboratory Operating platform	15	49x36x10	50x37x11	13/3.5	SPL001

Splicing Type Poly Spill Decks

The PE spill decks produced by SYSBEL is HDPE injection molded with precision moulds and therefore robust and reliable. The PE decks can prevent leakage of most chemicals, including acids, alkalis and other highly corrosive substances, thus making it more suitable for storing oil drums, drums of chemicals and other containers.

The PE decks comply with relevant standards of EPA and each country. They contribute to environmental protection during normal use by comprehensively reducing the risk of water environment and soil pollution. By adopting the reinforced structure design, the spill decks is featured with high load bearing capacity, high safety and high stability. The decks accurately restricts the gratings on the periphery, thereby facilitating easy installation, removal and cleaning of the gratings. Meanwhile, the gratings for PE decks are highly robust and corrosion resistant and have undergone surface roughening to effectively enhance surface friction, thus ensuring stable storage of drums. Moreover, holes in the gratings can effectively avoid possible accidental splash of dangerous chemicals during filling, subpackaging or storage. The decks has fork pockets 550 mm and 650 mm wide lengthwise to facilitate operations by the customer. With stacking restrictions on four sides, multiple decks can be accurately stacked and packaged for transport, which not only facilitates transfer with forklift but also saves space and transport costs as far as possible. There is room reserved for drain hole on the pallet, where hole can be made and drain valve installed according to local laws, making it convenient for customers to use.

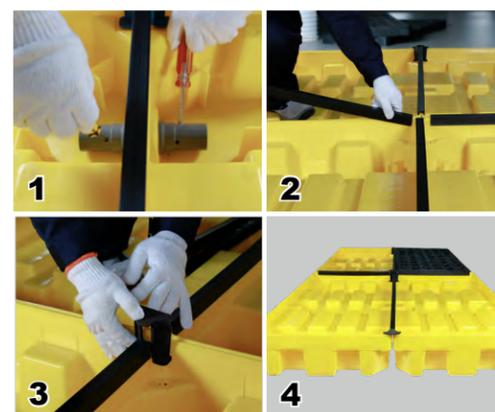
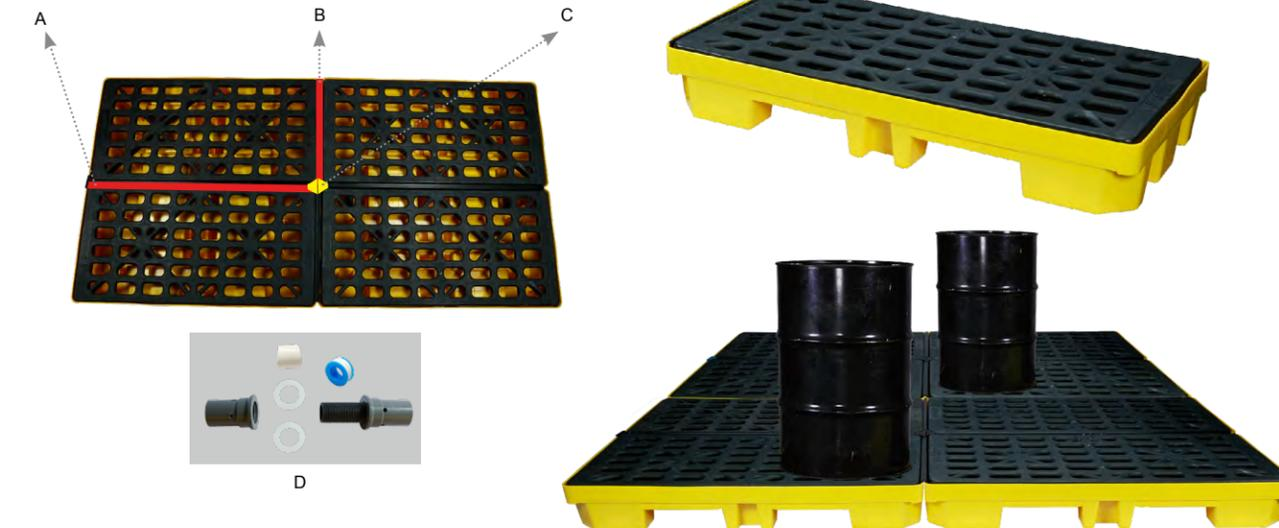

Accessories			
No.	Name	Function	Model
A	Connecting Strip Long Side	Fix Long Side, PP	SPP101-PJ01
B	Connecting Strip Short Side	Fix Short Side, PP	SPP101-PJ02
C	Connected Components	Connect Spill Decks for EPA	SPP101-PJ03
D	Poly Spill Deck Joint	Deine the Corner Positions, PP	SPP101-PJ04

* Chose by Decks Combination

Modular PE Spill Decks								
Capacity (Gal/L)	Certification	Material	Color	Load Bearing Capacity (kgs)	Overall Dimensions (LxWxH/cm)	Package Size (LxWxH/cm)	Configu-ration	Model
23/90	CE	PE	Yellow/black	1500	128x64x20	128x64x20	Grating*1 Pallet*1	SPP101-2

SPCC Spill Prevention, Containment & Control

IBC Poly Spill Pallet

- 1.The pallet is used for secondary leak-proof storage of chemical storage containers to avoid splashing or leaking when the containers are dispensed or stored. This product is specially used for leakage treatment of IBC square chemical tanks, and is suitable for preventing spills of mid-sized containers.
- 2.The product is suitable for leak-proof packaging, storage and transportation of most mid-sized containers.
- 3.The product is manufactured by 100% polyethylene, which has a seamless structure and is safe and reliable.
- 4.The product has the quality of acid-alkali, corrosion and weather resistance, which can effectively prevent the harm of the leakage of chemical liquids.
- 5.The pallet is solid and durable. With the design of reinforced curled edge, it has higher endurance, which can prevent collision and crack.
- 6.The stackable pallets design reduces storage space and transportation costs.
- 7.The product has forklift slots at the bottom, which can be carried by forklift and pallet jack from 4 directions, making the transportation easy and fast.
- 8.The product complies with EPA 40 CFR264.175 standards and NPDES regulations.



IBC Poly Spill Pallet							
Product	Number of IBC Drum	Capacity (Gal/L)	Loading Capacity (Kgs.)	Ext.Dimensions (H×L×W/cm)	Forklift Operation	Standard	Model
IBC Poly Spill Pallet	1	298/1130	1600	90×135×135	Quadrirectional operation	EPA 40 CFR 264.175	SPP105

Steel Spill Pallets

The steel spill pallet can also be used for storing, handling and separating oil drums and chemical drums. It is made of 3mm hot-rolled steel plate, stable and durable. The pallet body is coated with epoxy resin powder, forming a bright, dust-proof, rust-proof and moisture-proof surface. The fiberglass-reinforced grate of light weight, high strength, wear resistance and aging resistance can be removed for easy cleaning. The pallet can meet the handling needs of various forklifts. The cart type two-drum pallet, with large sump capacity, is more convenient to operate. It is designed in accordance with the leakage containing standards, and has passed the 100% leakage containing test. With the drum bracket at the pallet center, the load can be distributed, thus achieving higher performance. The 3/4"NPT (hex) ball valve in standard configuration is installed in the leakage hole in order to transfer the leaking liquid and facilitate the operation. The user is allowed to remove the bottom plug to fully discharge liquid and clean the pallet.



Steel Spill Pallets							
Product	Certification	200L Drum Quantity	Capacity (Gal/L)	Loading Capacity (Kgs.)	Ext.Dimensions (H×L×W/cm)	Forklift Operation	Model
Steel Spill Pallet(2 Drum)	CE	2	48/180	2000	36×125×70	Bidirectional operation	SPM202
Steel Spill Pallet(4 Drum)	CE	4	92/350	3500	36×136×130	Quadrirectional operation	SPM204
Mobile Steel Spill Pallet(with cart)	CE	2	48/180	1500	102×125×70	N/A	SPM222
Steel Spill Pallet(3 Drum)	CE	3	92/360	2700	33×200.5×82	Bidirectional operation	SPM304

IBC steel spill pallet							
Product	Certification	IBC Quantity	Capacity (Gal/L)	Loading Capacity (Kgs.)	Ext.Dimensions (H×L×W/cm)	Forklift Operation	Model
IBC steel spill pallet	CE	1	317/1200	3500	79×136×130	Quadrirectional operation	SPM112

Spill Control Accessories



Spill Control Accessories						
Product	Certification	Types for pallet	Product Use	Loading Capacity (Kgs.)	Ext.Dimensions (H×L×W/cm)	Model
Poly Spill Pallet Ramp	CE	SPP102 SPP104	The ramp serves for spill pallet makes the handling of bulk items easy.	454	30×120×80	SPP001
Poly Spill Deck Ramp	CE	SPP101 SPP103	It is dedicated to the spill deck. The supporting metal hook firmly connected the ramp with the deck. The ramp serves as an easy access to the transfer of drums and containers.	454	15×120×80	SPP012
Two-drum Poly Spill Deck Cart	CE	SPP101	Make up for the deficiency of the spill deck that cannot be handled with forklift, and make transportation and transfer of oil and chemical drums more flexible.	1500	102×131×63	SPP013

Waterproof Tape

1. Easy to use, fast, very suitable for emergency.
2. Be made of thick waterproof butyl rubber, has strong viscosity and can widely suitable for many kinds of emergent situations .
3. Thick aluminum film makes the product having excellent performance of strength ,fire resistance and wear-resistance.



Waterproof Tape			
Unfold Size (Length Width/mm)	Roll-up Size (Diameter Height/mm)	Material	Model
200*1000	60*200	aluminum film + butyl rubber	SPP021



White

- Dedicated to the absorption of oil, instead of water



Yellow

- Especially for absorbing acidic and corrosive liquids, or other unknown hazardous liquids (both oil and liquid)



Gray

- Universal type, absorbing both oil and water



Emergency Treatment for Chemical Spills Absorbents

SYSBEL Absorbent(pad, sock and pillow)with melt blown polypropylene (MBPP) features high absorption rate, rapid absorption, good cleaning effect, which don't react with polar, toxic, hazardous chemicals, and is safe to use, causing no harm to personal health. Waste disposal is low in cost, and clean-up of spilled liquid is simple.It is a good helper for your workplace cleaning!



Type	Product	Dimensions (cm)& Specifications	Packing H*W*D/cm	Qty Per Carton	Absorbency Per (Gal/L)	Model
Absorbent Pad	Oil-Only Absorbent Pad	50x40 (LxW) light, perforated	23x52x42	100 pads	16/60	OP0001W
	Hazmat Absorbent Pad					CP0001Y
	Universal Absorbent Pad					UP0001G
Poly-Back Absorbent Mat	Oil-Only Absorbent Pad	50x40 (LxW) heavy, perforated	42x52x42	100 pads	32/120	OP0002W
	Hazmat Absorbent Pad					CP0002Y
	Universal Absorbent Pad					UP0002G
Absorbent Sock	Oil-Only Poly-Back Absorbent Mat	50x40 (LxW)	30x52x42	100 pads	24/90	OM0001W
	Hazmat Poly-Back Absorbent Mat					CM0001Y
	Universal Poly-Back Absorbent Mat					UM0001G
Absorbent Boom	Oil-Only Absorbent Sock	7.6x120 (DIAMxL)	30x55x42	12 socks	15/57	OS0001W
	Hazmat Absorbent Sock					CS0001Y
	Universal Absorbent Sock					US0001G
Drum Mat	Oil-Only Absorbent Boom	12.7x300 (DIAMxL)	50x55x55	4 socks	24/90	OB0001W
	Hazmat Absorbent Boom					CB0001Y
	Universal Absorbent Boom					UB0001G
Absorbent Pillow	Oil-Only Drum Mat	55 (DIAM)	14x56x56	25 pieces	7/27	DOP001
	Hazmat Drum Mat					DCP001
	Universal Drum Mat					DUP001
Absorbent Roll	Oil-Only Absorbent Pillow	45x45x5 (LxWxH)	50x45x45	10 pillows	20/75	SOP001
	Hazmat Absorbent Pillow					SCP001
	Universal Absorbent Pillow					SUP001
Absorbent Roll	Oil-Only Absorbent Roll	5000x40 (LxW;perforated every 50cm Lengthwise, light)	42x38x38	1 roll	16/60	SOR001
	Hazmat Absorbent Roll					SCR001
	Universal Absorbent Roll					SUR001
	Oil-Only Absorbent Roll	5000x40 (LxW;perforated every 50cm Lengthwise, heavy)	42x55x55	1 roll	32/120	SOR002
	Hazmat Absorbent Roll					SCR002
	Universal Absorbent Roll					SUR002
	Universal Absorbent Roll	91x5000	91x55x55	1 roll	72/272	SUR003



Absorbent Mats

New!

Heavy Universal Absorbent Mat

Application:

- 1.Can absorb most industrial liquids - oils, coolants, solvents, water and others
- 2.Can be spread on the ground and the surface of the work table where no liquid is allowed to go deep to keep the environment clean.
- 3.Can be spread on the floor of the factory and warehouse to protect the floor from pollution and damage,keep the working environment dry and safe.
- 4.Can be spread under machines to protect the ground and prevent liquid leakage.
- 5.Can be spread around lathe,CNC machines ,to absorb sparking oil and coolant.

Product Features:

- 1.Made of multi-layer polypropylene fiber, Can absorb most industrial liquids - oils, coolants, solvents, water and others.
- 2.The unique anti-overflow layer can prevent any liquid leakage and keep the ground dry and safe.
- 3.The unique anti-overflow layer can prevent any liquid leakage and keep the ground dry and safe.
- 4.Excellent adhesive, and unique lamination process, stickup and firm, level not curly, can avoid the fall of damage due to fetter.
- 5.This product can help users to purify the working environment, avoid personnel slipping and improve the management level of the site

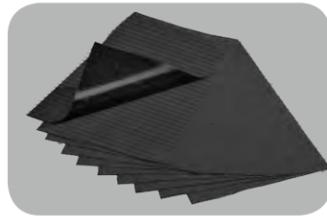

Heavy Universal Absorbent Mat

Product Name	Color	Absorbency (L/roll)	Product Packaging	External dimension (LxW/cm)	Package dimension (LxWxH/cm)	Model
Heavy universal absorbent mat	Dark Gray	Absorption up to 8L/box	10pieces/box	60 x 40	65 x 45 x 7	SUR004
Heavy universal absorbent mat	Dark Gray	Absorption up to 65L/bag	1 roll/bag	3000 x 80	85 x 45 x 45	SUR005

Heavy Durable Absorbent Mat

Application:

- 1.Can absorb most industrial liquids - oils, coolants, solvents, water and others.
- 2.Can be spread on the ground and the surface of the work table where no liquid is allowed to go deep to keep the environment clean.
- 3.Can be spread on the floor of the factory and warehouse to protect the floor from pollution and damage,keep the working environment dry and safe.
- 4.Can be spread under machines to protect the ground and prevent liquid leakage.
- 5.Can be spread around lathe, CNC machines and machinery maintenance site,to absorb sparking oil and coolant.
- 6.Can be spread on the aisle-ways and walkways, can stand up to tool trolley, forklift traffic.

Product Features:

- 1.It is made of polyester fiber, which wears well and can stand up to tool trolley, forklift traffic.
- 2.Excellent adsorption capacity, can absorb and lock oil, coolant, solvent, water and other liquids.
- 3.The unique anti-overflow layer can prevent any liquid leakage and keep the ground dry and safe.
- 4.Excellent adhesive, and unique lamination process, stickup and firm, level not curly, can avoid the fall of damage due to fetter.
- 5.Easy to lift, not easy to leave residual glue, fully protect the ground, reduce cleaning time.
- 6.This product can help users to purify the working environment, avoid personnel slipping and improve the management level of the site.

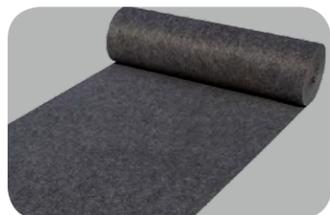

Heavy Durable Absorbent Mat

Product Name	Color	Absorbency (L/roll)	Product Packaging	External dimension (LxW/cm)	Package dimension (LxWxH/cm)	Model
Heavy absorbent mat roll (Without adhesive)	Black	Absorption up to 50L	1 roll / bag	3000 x 90	95 x 42 x 42	SUR006
Heavy absorbent mat roll (back gum)	Black	Absorption up to 50L	1 roll/bag	3000 x 90	95 x 45 x 45	SUR007

Industrial Wipes

SYSBEL Absorbent(pad, sock and pillow)with melt blown polypropylene (MBPP) features high absorption rate, rapid absorption, good cleaning effect, which don't react with polar, toxic, hazardous chemicals, and is safe to use, causing no harm to personal health. Waste disposal is low in cost, and clean-up of spilled liquid is simple.It is a good helper for your workplace cleaning!



CLEANROOM WIPES



INDUSTRIAL WIPES



INDUSTRIAL WIPING CLOTH



Product	Color	Packing specification	Single size	Style	Inside Box (LxWxH/cm)	Outside Box (LxWxH/cm)	Model	Details
Cleanroom Wipes	White	280/Box 60 boxes/ Carton	11cm*20cm	Removable	12.5*12*7.5	52.5*41*40	SWF101	1. Ultra low dust 2.100% primary wood pulp, high quality raw material 3.The paper is fine, to avoid rubbing on the surface 4.Prevent static electricity generation, through antistatic test 5.The strength of dry and wet condition is excellent and it is not easy to break 6.High efficiency water absorption, pure texture
Industrial Wiping	Yellow	420 pcs/roll 2 rolls/box	23cm*40cm	Roll		60*28.5*24.5	SWR201Y	1. Ultra low dust 2.100% primary wood pulp, high quality raw material 3.The paper is fine, to avoid rubbing on the surface 4.Prevent static electricity generation, through antistatic test 5.The strength of dry and wet condition is excellent and it is not easy to break 6.High efficiency water absorption, pure texture
	Yellow	60 pcs/pack 20 pack/box	27cm*30cm	Flat Sheet			SWF201Y	
Industrial Wiping	Blue	500 pcs/roll 2 rolls/box	23cm*34cm	Roll		60*28.5*24.5	SCR301B	1. High absorption performance; 2.High dry and wet strength, used in combination with solvents to meet daily wiping needs; 3.Do not leave dust after rubbing, do not fade; 4.Cleaning and wiping of liquid leaks, cleaning and protection of production equipment, maintenance and cleaning of workplaces; 5.Pass ROHS testing, professional quality; 6.FDA certified for direct access to food materials, silicone oil-free silicone certification; 7.It meets the sanitary standard of GB 15979-2002 disposable sanitary products.
	Blue	60 pcs/pack 18 pack/box	25cm*35cm	Flat Sheet			SCF301B	
	White	900 pcs/roll 1 roll/box	30cm*34cm	Roll			SCR321W	

SPCC Spill Prevention, Containment & Control

SPCC Spill Prevention, Containment & Controls

Universal Absorbent Drip Pan

Universal absorbent drip pan can be placed in most places where there is dripping, to protect the environment clean and safe.



Application:

1. Can absorb most liquids, such as oil, coolant, chemical solvent and water.
2. Suitable for emergency situations, placed under the machine, pipe, and flanges to absorb liquid drips;

Product Features:

1. Suitable for most dripping liquid situations, to keep the environment clean and safe.
2. The pan with highly absorbent polypropylene filler can hold maximum 3 liters of liquid drips.
3. The wide base makes it can be placed stably, won't tip over.
4. Flat structure, can be placed in low, narrow space.

Instructions:

1. Place the Absorbent Drip Pan under the place where the machine, pipe, faucet, etc., then catching the dripping liquid.
2. Please dispose of waste in accordance with local legal requirements, personnel slipping and improve the management level of the site

Universal Absorbent Drip Pan				
Color	External dimension (LxW/cm)	Package dimension (LxWxH/cm)	Absorbency (Gal/L/Box)	Model
Black	7×30×30	42×64×33	9.6/36	DUP002

Overpack Salvage Drum

This product is applicable to temporary storage and transportation of hazardous wastes (such as flammable, corrosive and toxic substances), and widely applied in secondary packaging, transportation, transfer and spill handling, etc. It is manufactured by one-time rotational molding and can realize 100% spill protection. It also has good toughness. Polyethylene is resistant to UV rays, corrosion and most chemicals. The emergency treatment drum can be nested to reduce the storage space and transportation costs.



SYD950

SYD200



SYD001

Steel Dolly for Overpack Salvage Drum

The 95Gal overpack salvage drum is slightly heavy in emergency treatment of chemical spill. In order to improve the mobility, the flexible sliding rails can be used. Two universal casters can be fixed at any time to prevent bounce in operation. Note: It is recommended to apply the rails only to the drum with spill kits.

Overpack Salvage Drum

Product	Certification	Capacity (Gal/L)	Loading Capacity (Kgs.)	Top Diameter(cm)		Bottom Diameter(cm)		Height(cm)		Ext.Dimensions (Height×Diameter/cm)	Model
				Outer	Inner	Outer	Inner	Outer	Inner		
Overpack Salvage Drum(95Gal)	CE	95/360	292.5	78.5	72.5	64.5	62.5	104	97	104x78.5	SYD950
Overpack Salvage Drum(20Gal)	CE	20/75.7	60	57	51	48	45	60.5	58	60.5x57	SYD200

Steel Dolly for Overpack Salvage Drum

Product	Capacity (Gal/L)	Bottom Diameter(cm)		Height(cm)	Ext.Dimensions (Height×Diameter/cm)	Model
		Outer	Inner	Inner		
Steel Dolly for Overpack Salvage Drum	100	67	66.5	2	8x67	SYD001

20Gal-Drum Overpack Spill Kit

With a variety of adsorption materials, help you respond quickly to unexpected incidents, and can isolate hazardous waste and contaminants with the spill barrel to prevent secondary leakage hazard, which is suitable for large-scale spill.



SYK202 (Oil Only)

SYK201 (Chemical Only)

SYK200 (Universal)

SYK203 (Universal)

20Gal-Drum Overpack Spill Kit	Spill Capacity (Gal/L) : 21.5/81
	1 pc 20-gallon overpack salvage drum 25 pcs 50cm×40cm absorbent Pad, 6 pcs 7.6cm×120cm absorbent sock, 5 pcs 45cm×45cm absorbent pillow, 3 pcs hazamat disposal bags, 3 pcs cable tie, 1 pc Rax-9202 safety goggle, 1 pc safety gloves, 1 pc user manual, weight (Kgs.):11.3
20Gal-Drum Overpack Wiping Adsorption Spill Kit (Universal)	Spill Capacity(Gal/L): 75~83L/20~22Gal
	1 20Gal-Drum Overpack Spill Kit, 6 pcs 7.6cm×120cm absorbent sock, 5 pcs 45cm×45cm absorbent pillow, 1 pcs Industrial Wipe , 2 pcs Industrial Wiping Cloth(Blue), 3 pcs hazamat disposal bags, 1 pc Rax-9202 safety goggle, 1 pc safety gloves, 3 pcs rope

95Gal-Drum Overpack Spill Kits

With a variety of adsorption materials, help you respond quickly to unexpected incidents, and can isolate hazardous waste and contaminants with the spill drum to prevent secondary leakage hazard, which is suitable for large-scale spill.



Acquired CE Certification, comply with the regulations of EPA 40 CFR 264.175 of EPA and SPCC as well as U.S. NPDES.



SYK952 (Oil Only)



SYK951 (Chemical Only)



SYK950 (Universal)

95Gal-Drum Overpack Spill Kits	Spill Capacity (Gal/L) :80/302
	1 pc 95-gallon overpack salvage drum 125 pcs 50cm×40cm absorbent pad, 24 pcs 7.6cm×120cm absorbent sock, 15 pcs 45cm × 45cm absorbent pillow, 10 pcs hazamat disposal bags, 10 pcs cable tie, 1 pair of Ra×-9202 safety goggles, 1 pair of safety gloves, 1 pc user manual, weight (Kgs.):41

65-Gallon Wheeled Poly-Overpack Salvage Drum

SYSBEL 65-Gallon Wheeled Poly-Overpack Salvage Drums are special containers which are suitable for temporary storage and transport of hazardous waste. Widely used in secondary packaging, transportation, emergency spill treatment to eliminate hazardous materials and secondary leakage occurs. Built-in wheels eliminate the need for a separate dolly or other transport; Help to provide you with the most effective and low cost safety solutions.



SYD650



SYK652 (Oil Only)



SYK651 (Chemical Only)



SYK650 (Universal)

65-Gallon Wheeled Poly-Overpack Salvage Drum	Spill Capacity (Gal/L) : 60/228
	1 pc 65-gallon wheeled poly-overpack salvage Drum 125 pcs 50cm×40cm absorbent pad, 16 pcs 7.6cm×120cm absorbent sock, 10 pcs 45cm×45cm absorbent pillow, 10 pcs hazamat disposal bags, 10 pcs cable tie, 1 pair of Ra×-9202 safety goggles, 1 pair of safety gloves, 1 pc user manual, weight (Kgs.):25.5

65-Gallon Wheeled Poly-Overpack Salvage Drum							
Material	Capacity (Gal/L)	Ext. size(H*W*Dcm)	Handle to Floor Distance(cm)	Max.External Diameter(cm)	Opening Diameter	Loading (kgs)	Model
Poplyethylene	65/246	117*71*78.5	96.5	71	62.5	300	SYD650

Mobile Spill Kit

Mobile spill kits, with a variety of absorbents combination to help you respond quickly to unexpected incidents. Wheelie bin helps you to send SYSBEL professional adsorbent materials to every corner of the factory, to respond to spills accident or sewage treatments in the factory, which is suitable for medium-scale spill.



SKIT002W (Oil Only)



SKIT002Y (Chemical Only)



SKIT002G (Universal)

Mobile Spill Kit	Spill Capacity (Gal/L) :45/170
	1 pc 240L wheeled bin 125 pcs 50cm×40cm absorbent pad, 12 pcs 7.6cm×120cm absorbent sock, 5 pcs 45cm×45cm absorbent pillow, 5 pcs hazamat disposal bags, 5 pcs cable tie, 1 pair of Rax-9202 safety goggles, 1 pair of safety gloves, 1 pc user manual, weight (Kgs.):24.1

Portable Spill Kit

Carring flexible, suitable for small leaking.



SKIT001W (Oil Only)



SKIT001Y (Chemical Only)



SKIT001G (Universal)

Portable Spill Kit	Spill Capacity (Gal/L) : 11.5/43.5
	1 pc portable bag 25 pcs 50cm×40cm absorbent pad, 6 pcs 7.6cm×120cm absorbent sock, 1 pc hazamat disposal bags, 1 pc cable tie, 1 pair of Ra×-9202 safety goggles, 1 pair of safety gloves, 1 pc user manual, weight(Kgs.):2.75

Spill Kits Refill

Rapid response to an emergency can be made by combining various absorbing materials, without purchasing new wheelie bins or salvage drums. The product can be directly used with the existing package to rapidly and efficiently isolate hazardous wastes and contaminants.



SKS001W (Oil Only)



SKS001Y (Chemical Only)



SKS001G (Universal)

Spill Kits Refills	Spill Capacity (Gal/L) : 10/38
	20 pcs 50cm×40cm absorbent pad, 2 pcs 7.6cm×120cm absorbent sock, 2 pcs 45cm×45cm absorbent pillow, 2 pcs big hazamat disposal bags, 2 pcs medium hazamat disposal bags, 4 pcs cable tie, 4 pair of safety gloves, 1 pc user manual, weight (Kgs.):4.5

Spill Kits in Cart

At the production and construction sites, the occurrence of leaks is unavoidable, and even if you are more and more careful, there will be accidental dangers. Especially for liquid goods that are easily polluted or of high value (like chemical storage tanks, oil drums, etc.), we must take adequate precautions for prevention and treatment in advance. If the treatment is not timely or improper after the leakage occurs, it will affect the cleanliness of the working environment, may cause safety accidents such as falls, and cause pollution to the working environment. If dangerous chemical liquids flow into the sewer, it will seriously endanger people's lives.



Spill Kits Cart						
Material	Certification	Door Type	Color	Product Size (H*W*D/cm)	Packing Size (H*W*D/cm)	Model
High-quality galvanized steel	CE	Single	Yellow	113.5 x 65 x 55	129 x 79 x 63	WA940640
Spill Kits in Cart		Spill Capacity (Gal/L) : 48~56 / 181~212 1 Trolley Manual of Accidental Release Measures, 100 pcs 50cm×40cm absorbent pad, 4 pcs 45cm×45cm absorbent pillow, 4 pcs 7.6cm×120cm absorbent sock, 5 pcs hazamat disposal bags and ropes, 1 pair of Ra×-9202 safety goggles, 1 pair of safety gloves, 1 Absorbent Roll, 1 pc user manual				

Polyethylene Disposal Bags

- Tough polyethylene bags resist punctures, tearing and blowouts
- Reliable bag hazardous or contaminated waste for disposal
- Durable 0.08mm thickness
- Ideal for lining drums or short-term storage of saturated absorbents and other waste products
- Bright yellow bags are signally labeled "CAUTION Hazardous Material - Handle With Care"



Polyethylene Disposal Bags				
Product	Description	Dimensions	Description	Model
Polyethylene Disposal Bags	Medium	79x65.5	Reliable bag hazardous or contaminated waste for disposal	SYB200
Polyethylene Disposal Bags	Large	150x90	Reliable bag hazardous or contaminated waste for disposal	SYB950

PVC Float-Type Spill Containment Boom

- with high frequency of welding technique, high tensile strength
- good waverider, stable, and well containment
- two types connection: ASTM aluminous connection / belt & rope & shackle, easy to join and operate



PVC Float-Type Spill Containment Boom								
Feeboard (mm)	Daft (mm)	Section Length (m)	Working Condition					Model
			Tention Streight(kn)	Wave Height(m)	Wind Speed(m/s)	Flow Rate(kn)	Section Weight(kg)	
140	370	20	30	0.3	8	1	45	FTB001
270	380	20	40	0.5	10	1.5	60	FTB002
290	380	20	40	0.5	10	1.5	70	FTB003
310	470	20	60	1	15	1.5	100	FTB004
510	740	20	130	2	20	2	150	FTB005

Using Guide of Spill Emergency Treatment Equipments

1. Spill Sources and Risk Judgments

Look for spill source and determine the hazards of the materials: assess the risks of leakage based on chemical labels and MSDS of the spilled materials (including flammable, explosive, reactive and toxic, etc).



2. Personal Protective Equipment (PPE) Arrangements

In spill treatment site, you should wear necessary personal protective equipment (including protective clothing, respirators, gloves, glasses, chemical boots, etc.). If you cannot determine the source of spilled material, you need to consider the possibility of the occurrence of the most serious consequences, to arrange the PPE for the serious consequence, so as to safely deal with spills.



3. Spill Prevention and Control

Control the spill, by closing or restricting valves, or taking appropriate measures. If container spills occur, it is noted that the container should be kept in an upright position.



4. Spill Treatment

Assess the level of spill. After spill area is controlled, use appropriate **SYSBEL** spill kits in a timely manner. The absorbent pads in the package are for small-scale spill; Socks can absorb spill, overlapping circle is for controlling leakage range, socks and pillows can be used to deal with large-scale leakage. The absorbent materials or hazardous materials after treatment should be properly transferred to the chemical-proof disposal bag or sealed by **SYSBEL** overpack salvage drum. As required by the local regulations, they will be transferred to the professional waste disposal facility for special treatment.



5. Pollution Elimination

Clean personal protective equipment to prevent secondary pollution.



6. Spill Treatment Report

Prepare the treatment report of spills, and report to upper-level management.

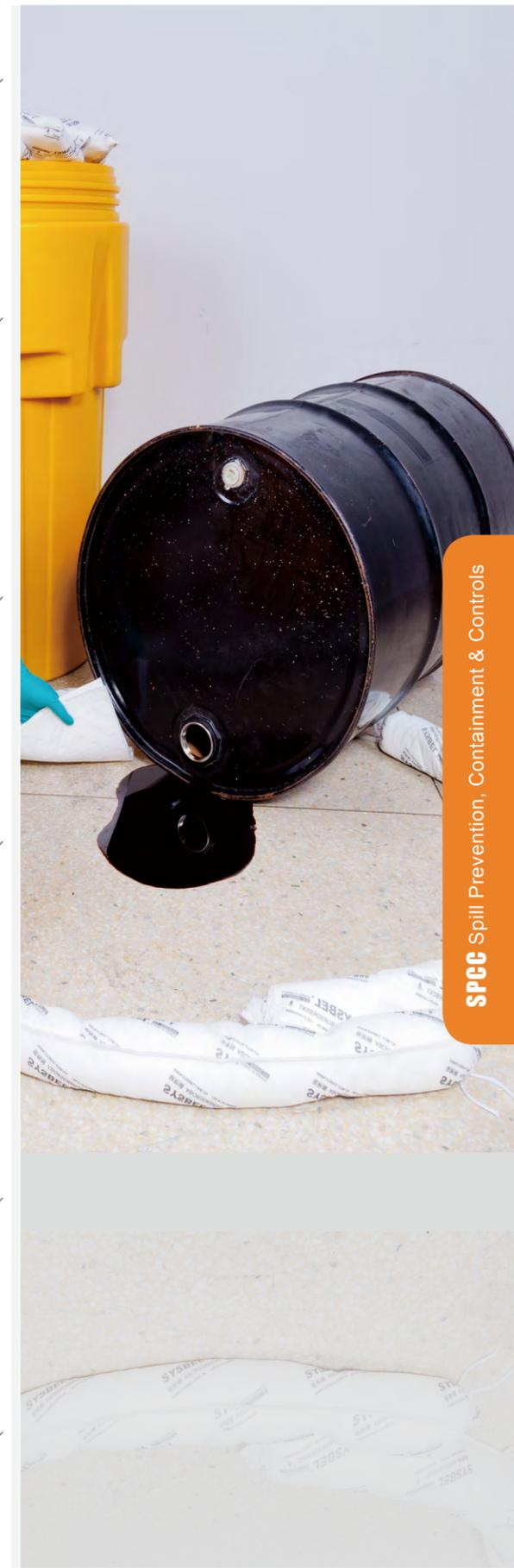



Special Protective Products

SYSBEL There are many dangers in the production, scientific research, teaching and other operations, which threaten the personal safety and health of the operator. SYSBEL's special protection series products are a kind of defensive equipment for the operator during the operation process. Health provides better protection. SYSBEL special protection series products include but are not limited to the following types of products: eye and face protection products, first aid kits, safety mats, anti-collision system products, etc.



Eye/Face Wash

SYSBEL's new nozzle heads colligate traditional aerators and spray heads with holes. Zero velocity point provides more comfort and control for effective sweeping hazardous contaminants away from the face and eyes using a soft aerated stream for eye wash and independently angled face wash stream for optimum coverage. This series of products fully complies with ANSI Z358.1-2014 and AS 4775-2007, and has been tested and approved by CSA.

- The unique nozzle design is adopted. The same height can be maintained under certain water pressure, to avoid the operating obstacles caused by water pressure.
- The nozzle can be used for spraying two kinds of water at the same time, with balanced heights. The water flow is steady and uniform due to the built-in flow limiter.
- The aerator with a coin slot is easy to remove and install, and thus simple to clean and maintain.
- The dust-proof cover can protect the nozzle from being contaminated by dust in the air. Once the eyewash is started, the dust-proof cover will be opened automatically under water flow.
- The copper nut is built in the 304SS nozzle base and connected to the horn elbow, and its strength is enough to allow repeated removal and installation and ensure longer service life.
- The nozzle is made of AES engineering plastic which is superior to ABS engineering plastic, and has outstanding features of weather resistance, high rigidity, corrosion resistance, UV resistance, etc.
- The main fittings and other accessories are made of 304 stainless steel and applicable to adverse workplaces.
- The bright yellow plastic is used to facilitate observation and identification.
- The quick connector is equipped with a built-in filter to prevent debris or impurities from flowing into the nozzle, in order to avoid secondary damage to the eyes. In addition, the connector is easy to operate, which is conducive for cleaning and maintenance on a regular basis.
- The eye/face wash series fully comply with ANSI Z358.1-2014 and AS 4775-2007, and has been tested and approved by CSA.



It complies with the regulations in ANSI Z358.1-2014 standard and OSHA 29 CFR 1910.151(C) issued by ANSI has acquired CE Certification

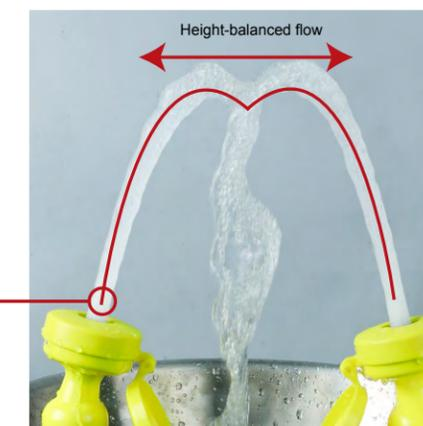

Shower head

SYSBEL's safety showers provide conical water pattern and gently deliver large volumes of water to realize complete decontamination without injury to skin. It ensures the fastest, most effective removal of contaminants in emergency. The shower equipment complies with the standard of ANSI Z358.1-2014 and approved by CSA.

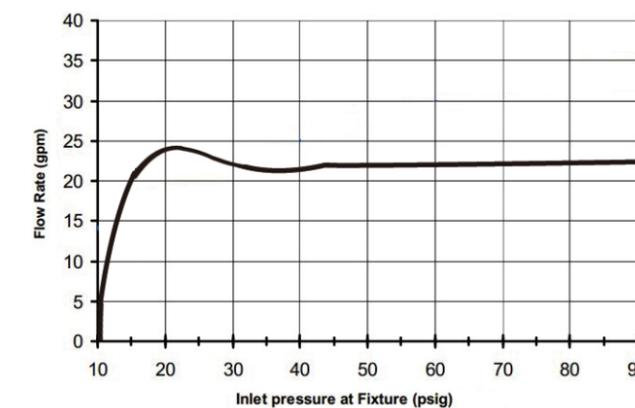
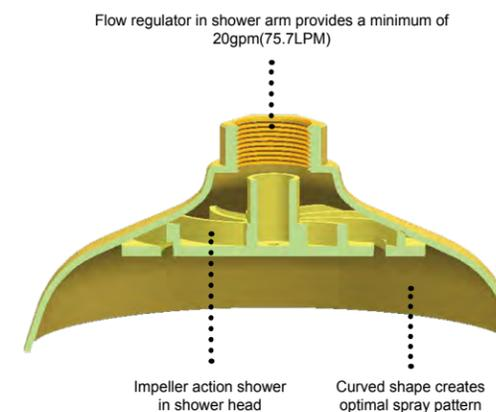

NOTE:

Spinkler head features flow regulator (exceeds minimum water flow of 20 GPM (75.7LPM) at 30 PSI (2.0 bar)) in shower arm pipe, which not only delivering adequate and stable flushing fluid, but conserving water as well as helping users to decontaminate more effectively.



QUICK COMPLIANCE GUIDE Combination Unit

- 1 Valve mechanism activates in one second or less; it stays open until manually closed. (Section 4.2, 5.2, 6.1.4, 6.2)
- 2 Be connected to a system capable supplying adequate flushing fluid when all components are operated simultaneously. (Section 4.5.5, 7.4.4)
- 3 Height of the flushing fluid column pattern shall be between 82" (208.3cm) and 96" (243.8cm) above floor. (Section 4.1.3, 4.5.4)
- 4 Watersupply shall be sufficient to supply at least 20GPM (75.7LPM) for 15 minutes. (Section 4.1.2, 4.5.5)
- 5 Valve actuator shall be located not more than 175.3cm (69") above floor. (Section 4.2)
- 6 The diameter shall be minimum of 50.8cm (20") at 152.4cm (60") above floor. (Section 4.1.4)
- 7 Center of the flushing fluid pattern shall be at least 16" (40.6cm) from any obstruction. (Section 4.1.4, 4.5.4)
- 8 Water flow pattern shall be positioned between 33" (83.8cm) and 53" (134.6cm) from the level on which user stands and 6" (15.3cm) minimum from the wall or nearest obstruction. (Section 5.4.4, 6.4.4)
- 9 Deliver at least 3.0 gallons (11.4liters) of water per minute for 15-minute. (Section 6.1.6, 6.4.5)
- 10 Constructed of materials that will not corrode in the presence of the flushing fluid. (Section 7.1.1, 7.1.2, 7.1.3)
- 11 Located 10 seconds or 55 feet from contaminants or hazardous materials. Locate on the same level as hazard and free of obstructions. (Section 7.4.2, B5)
- 12 Protect nozzle head from airborne contamination, dust covers shall be removed by water flow immediately. (Section 5.1.3, 6.1.3)
- 13 Provided flushing fluid to both eye and face simultaneously at a velocity low enough without injury to skin. (Section 5.1.1, 6.1.1)

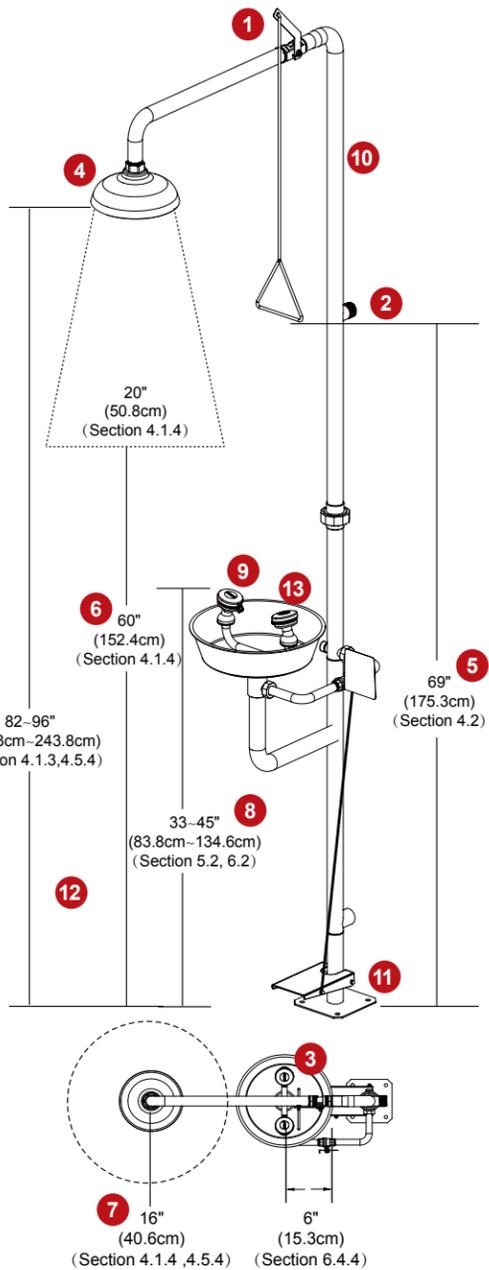

Combination Unit

- Application: Provide full-body relief from contamination fastly and effectively
- Materials: AES plastic + 304 Stainless Steel
- AES plastic has weather resistance properties and applies to indoors or outdoors
- With good acid-proof, alkali prevention performances, 304SS is ideal for harsh environment
- Pull rod with triangular handle is easy to operate for showers
- The design with equal length of main pipes makes packaging more compact so that helps to save space and cost
- Equipped with flat washer in quick coupling to prevent leakage between joints and fitting
- Flow regulator is built in shower arm tube
- The shower head delivers a large volume flushing fluid spread evenly in a precise pattern and controlled flow rate.
- Activated by push handle or foot pedal easily
- The coin slot hidden faucet aerator is easy to remove and clean
- Dust cover is removed once unit started
- Comply with ANSI Z358.1-2014 and AS 4775-2007



Mounting Bracket

- SYSBEL provides mounting brackets for installing shower stanchion firmly.



Technical Services
International Compliance Management

VERIFICATION OF COMPLIANCE

Certificate No.: S21763002

Applicant: SHANGHAI SYSBEL INDUSTRIAL TECHNOLOGY CO., LTD.

Address of Applicant: BLD 26, 16 SA, NO.1000 JIANGSU RD, PUDONG NEW DISTRICT, SHANGHAI, CHINA

Manufacturer: SHANGHAI SYSBEL INDUSTRIAL TECHNOLOGY CO., LTD.

Address of Manufacturer: BLD 26, 16 SA, NO.1000 JIANGSU RD, PUDONG NEW DISTRICT, SHANGHAI, CHINA

Product Description: SAFETY CABINET

Type and Model: SYSBEL100, SYSBEL150, SYSBEL200, SYSBEL250, SYSBEL300, SYSBEL350, SYSBEL400, SYSBEL450, SYSBEL500, SYSBEL550, SYSBEL600, SYSBEL650, SYSBEL700, SYSBEL750, SYSBEL800, SYSBEL850, SYSBEL900, SYSBEL950, SYSBEL1000, SYSBEL1050, SYSBEL1100, SYSBEL1150, SYSBEL1200, SYSBEL1250, SYSBEL1300, SYSBEL1350, SYSBEL1400, SYSBEL1450, SYSBEL1500, SYSBEL1550, SYSBEL1600, SYSBEL1650, SYSBEL1700, SYSBEL1750, SYSBEL1800, SYSBEL1850, SYSBEL1900, SYSBEL1950, SYSBEL2000, SYSBEL2050, SYSBEL2100, SYSBEL2150, SYSBEL2200, SYSBEL2250, SYSBEL2300, SYSBEL2350, SYSBEL2400, SYSBEL2450, SYSBEL2500, SYSBEL2550, SYSBEL2600, SYSBEL2650, SYSBEL2700, SYSBEL2750, SYSBEL2800, SYSBEL2850, SYSBEL2900, SYSBEL2950, SYSBEL3000, SYSBEL3050, SYSBEL3100, SYSBEL3150, SYSBEL3200, SYSBEL3250, SYSBEL3300, SYSBEL3350, SYSBEL3400, SYSBEL3450, SYSBEL3500, SYSBEL3550, SYSBEL3600, SYSBEL3650, SYSBEL3700, SYSBEL3750, SYSBEL3800, SYSBEL3850, SYSBEL3900, SYSBEL3950, SYSBEL4000, SYSBEL4050, SYSBEL4100, SYSBEL4150, SYSBEL4200, SYSBEL4250, SYSBEL4300, SYSBEL4350, SYSBEL4400, SYSBEL4450, SYSBEL4500, SYSBEL4550, SYSBEL4600, SYSBEL4650, SYSBEL4700, SYSBEL4750, SYSBEL4800, SYSBEL4850, SYSBEL4900, SYSBEL4950, SYSBEL5000, SYSBEL5050, SYSBEL5100, SYSBEL5150, SYSBEL5200, SYSBEL5250, SYSBEL5300, SYSBEL5350, SYSBEL5400, SYSBEL5450, SYSBEL5500, SYSBEL5550, SYSBEL5600, SYSBEL5650, SYSBEL5700, SYSBEL5750, SYSBEL5800, SYSBEL5850, SYSBEL5900, SYSBEL5950, SYSBEL6000, SYSBEL6050, SYSBEL6100, SYSBEL6150, SYSBEL6200, SYSBEL6250, SYSBEL6300, SYSBEL6350, SYSBEL6400, SYSBEL6450, SYSBEL6500, SYSBEL6550, SYSBEL6600, SYSBEL6650, SYSBEL6700, SYSBEL6750, SYSBEL6800, SYSBEL6850, SYSBEL6900, SYSBEL6950, SYSBEL7000, SYSBEL7050, SYSBEL7100, SYSBEL7150, SYSBEL7200, SYSBEL7250, SYSBEL7300, SYSBEL7350, SYSBEL7400, SYSBEL7450, SYSBEL7500, SYSBEL7550, SYSBEL7600, SYSBEL7650, SYSBEL7700, SYSBEL7750, SYSBEL7800, SYSBEL7850, SYSBEL7900, SYSBEL7950, SYSBEL8000, SYSBEL8050, SYSBEL8100, SYSBEL8150, SYSBEL8200, SYSBEL8250, SYSBEL8300, SYSBEL8350, SYSBEL8400, SYSBEL8450, SYSBEL8500, SYSBEL8550, SYSBEL8600, SYSBEL8650, SYSBEL8700, SYSBEL8750, SYSBEL8800, SYSBEL8850, SYSBEL8900, SYSBEL8950, SYSBEL9000, SYSBEL9050, SYSBEL9100, SYSBEL9150, SYSBEL9200, SYSBEL9250, SYSBEL9300, SYSBEL9350, SYSBEL9400, SYSBEL9450, SYSBEL9500, SYSBEL9550, SYSBEL9600, SYSBEL9650, SYSBEL9700, SYSBEL9750, SYSBEL9800, SYSBEL9850, SYSBEL9900, SYSBEL9950, SYSBEL10000, SYSBEL10005, SYSBEL10010, SYSBEL10015, SYSBEL10020, SYSBEL10025, SYSBEL10030, SYSBEL10035, SYSBEL10040, SYSBEL10045, SYSBEL10050, SYSBEL10055, SYSBEL10060, SYSBEL10065, SYSBEL10070, SYSBEL10075, SYSBEL10080, SYSBEL10085, SYSBEL10090, SYSBEL10095, SYSBEL10100, SYSBEL10105, SYSBEL10110, SYSBEL10115, SYSBEL10120, SYSBEL10125, SYSBEL10130, SYSBEL10135, SYSBEL10140, SYSBEL10145, SYSBEL10150, SYSBEL10155, SYSBEL10160, SYSBEL10165, SYSBEL10170, SYSBEL10175, SYSBEL10180, SYSBEL10185, SYSBEL10190, SYSBEL10195, SYSBEL10200, SYSBEL10205, SYSBEL10210, SYSBEL10215, SYSBEL10220, SYSBEL10225, SYSBEL10230, SYSBEL10235, SYSBEL10240, SYSBEL10245, SYSBEL10250, SYSBEL10255, SYSBEL10260, SYSBEL10265, SYSBEL10270, SYSBEL10275, SYSBEL10280, SYSBEL10285, SYSBEL10290, SYSBEL10295, SYSBEL10300, SYSBEL10305, SYSBEL10310, SYSBEL10315, SYSBEL10320, SYSBEL10325, SYSBEL10330, SYSBEL10335, SYSBEL10340, SYSBEL10345, SYSBEL10350, SYSBEL10355, SYSBEL10360, SYSBEL10365, SYSBEL10370, SYSBEL10375, SYSBEL10380, SYSBEL10385, SYSBEL10390, SYSBEL10395, SYSBEL10400, SYSBEL10405, SYSBEL10410, SYSBEL10415, SYSBEL10420, SYSBEL10425, SYSBEL10430, SYSBEL10435, SYSBEL10440, SYSBEL10445, SYSBEL10450, SYSBEL10455, SYSBEL10460, SYSBEL10465, SYSBEL10470, SYSBEL10475, SYSBEL10480, SYSBEL10485, SYSBEL10490, SYSBEL10495, SYSBEL10500, SYSBEL10505, SYSBEL10510, SYSBEL10515, SYSBEL10520, SYSBEL10525, SYSBEL10530, SYSBEL10535, SYSBEL10540, SYSBEL10545, SYSBEL10550, SYSBEL10555, SYSBEL10560, SYSBEL10565, SYSBEL10570, SYSBEL10575, SYSBEL10580, SYSBEL10585, SYSBEL10590, SYSBEL10595, SYSBEL10600, SYSBEL10605, SYSBEL10610, SYSBEL10615, SYSBEL10620, SYSBEL10625, SYSBEL10630, SYSBEL10635, SYSBEL10640, SYSBEL10645, SYSBEL10650, SYSBEL10655, SYSBEL10660, SYSBEL10665, SYSBEL10670, SYSBEL10675, SYSBEL10680, SYSBEL10685, SYSBEL10690, SYSBEL10695, SYSBEL10700, SYSBEL10705, SYSBEL10710, SYSBEL10715, SYSBEL10720, SYSBEL10725, SYSBEL10730, SYSBEL10735, SYSBEL10740, SYSBEL10745, SYSBEL10750, SYSBEL10755, SYSBEL10760, SYSBEL10765, SYSBEL10770, SYSBEL10775, SYSBEL10780, SYSBEL10785, SYSBEL10790, SYSBEL10795, SYSBEL10800, SYSBEL10805, SYSBEL10810, SYSBEL10815, SYSBEL10820, SYSBEL10825, SYSBEL10830, SYSBEL10835, SYSBEL10840, SYSBEL10845, SYSBEL10850, SYSBEL10855, SYSBEL10860, SYSBEL10865, SYSBEL10870, SYSBEL10875, SYSBEL10880, SYSBEL10885, SYSBEL10890, SYSBEL10895, SYSBEL10900, SYSBEL10905, SYSBEL10910, SYSBEL10915, SYSBEL10920, SYSBEL10925, SYSBEL10930, SYSBEL10935, SYSBEL10940, SYSBEL10945, SYSBEL10950, SYSBEL10955, SYSBEL10960, SYSBEL10965, SYSBEL10970, SYSBEL10975, SYSBEL10980, SYSBEL10985, SYSBEL10990, SYSBEL10995, SYSBEL11000, SYSBEL11005, SYSBEL11010, SYSBEL11015, SYSBEL11020, SYSBEL11025, SYSBEL11030, SYSBEL11035, SYSBEL11040, SYSBEL11045, SYSBEL11050, SYSBEL11055, SYSBEL11060, SYSBEL11065, SYSBEL11070, SYSBEL11075, SYSBEL11080, SYSBEL11085, SYSBEL11090, SYSBEL11095, SYSBEL11100, SYSBEL11105, SYSBEL11110, SYSBEL11115, SYSBEL11120, SYSBEL11125, SYSBEL11130, SYSBEL11135, SYSBEL11140, SYSBEL11145, SYSBEL11150, SYSBEL11155, SYSBEL11160, SYSBEL11165, SYSBEL11170, SYSBEL11175, SYSBEL11180, SYSBEL11185, SYSBEL11190, SYSBEL11195, SYSBEL11200, SYSBEL11205, SYSBEL11210, SYSBEL11215, SYSBEL11220, SYSBEL11225, SYSBEL11230, SYSBEL11235, SYSBEL11240, SYSBEL11245, SYSBEL11250, SYSBEL11255, SYSBEL11260, SYSBEL11265, SYSBEL11270, SYSBEL11275, SYSBEL11280, SYSBEL11285, SYSBEL11290, SYSBEL11295, SYSBEL11300, SYSBEL11305, SYSBEL11310, SYSBEL11315, SYSBEL11320, SYSBEL11325, SYSBEL11330, SYSBEL11335, SYSBEL11340, SYSBEL11345, SYSBEL11350, SYSBEL11355, SYSBEL11360, SYSBEL11365, SYSBEL11370, SYSBEL11375, SYSBEL11380, SYSBEL11385, SYSBEL11390, SYSBEL11395, SYSBEL11400, SYSBEL11405, SYSBEL11410, SYSBEL11415, SYSBEL11420, SYSBEL11425, SYSBEL11430, SYSBEL11435, SYSBEL11440, SYSBEL11445, SYSBEL11450, SYSBEL11455, SYSBEL11460, SYSBEL11465, SYSBEL11470, SYSBEL11475, SYSBEL11480, SYSBEL11485, SYSBEL11490, SYSBEL11495, SYSBEL11500, SYSBEL11505, SYSBEL11510, SYSBEL11515, SYSBEL11520, SYSBEL11525, SYSBEL11530, SYSBEL11535, SYSBEL11540, SYSBEL11545, SYSBEL11550, SYSBEL11555, SYSBEL11560, SYSBEL11565, SYSBEL11570, SYSBEL11575, SYSBEL11580, SYSBEL11585, SYSBEL11590, SYSBEL11595, SYSBEL11600, SYSBEL11605, SYSBEL11610, SYSBEL11615, SYSBEL11620, SYSBEL11625, SYSBEL11630, SYSBEL11635, SYSBEL11640, SYSBEL11645, SYSBEL11650, SYSBEL11655, SYSBEL11660, SYSBEL11665, SYSBEL11670, SYSBEL11675, SYSBEL11680, SYSBEL11685, SYSBEL11690, SYSBEL11695, SYSBEL11700, SYSBEL11705, SYSBEL11710, SYSBEL11715, SYSBEL11720, SYSBEL11725, SYSBEL11730, SYSBEL11735, SYSBEL11740, SYSBEL11745, SYSBEL11750, SYSBEL11755, SYSBEL11760, SYSBEL11765, SYSBEL11770, SYSBEL11775, SYSBEL11780, SYSBEL11785, SYSBEL11790, SYSBEL11795, SYSBEL11800, SYSBEL11805, SYSBEL11810, SYSBEL11815, SYSBEL11820, SYSBEL11825, SYSBEL11830, SYSBEL11835, SYSBEL11840, SYSBEL11845, SYSBEL11850, SYSBEL11855, SYSBEL11860, SYSBEL11865, SYSBEL11870, SYSBEL11875, SYSBEL11880, SYSBEL11885, SYSBEL11890, SYSBEL11895, SYSBEL11900, SYSBEL11905, SYSBEL11910, SYSBEL11915, SYSBEL11920, SYSBEL11925, SYSBEL11930, SYSBEL11935, SYSBEL11940, SYSBEL11945, SYSBEL11950, SYSBEL11955, SYSBEL11960, SYSBEL11965, SYSBEL11970, SYSBEL11975, SYSBEL11980, SYSBEL11985, SYSBEL11990, SYSBEL11995, SYSBEL12000, SYSBEL12005, SYSBEL12010, SYSBEL12015, SYSBEL12020, SYSBEL12025, SYSBEL12030, SYSBEL12035, SYSBEL12040, SYSBEL12045, SYSBEL12050, SYSBEL12055, SYSBEL12060, SYSBEL12065, SYSBEL12070, SYSBEL12075, SYSBEL12080, SYSBEL12085, SYSBEL12090, SYSBEL12095, SYSBEL12100, SYSBEL12105, SYSBEL12110, SYSBEL12115, SYSBEL12120, SYSBEL12125, SYSBEL12130, SYSBEL12135, SYSBEL12140, SYSBEL12145, SYSBEL12150, SYSBEL12155, SYSBEL12160, SYSBEL12165, SYSBEL12170, SYSBEL12175, SYSBEL12180, SYSBEL12185, SYSBEL12190, SYSBEL12195, SYSBEL12200, SYSBEL12205, SYSBEL12210, SYSBEL12215, SYSBEL12220, SYSBEL12225, SYSBEL12230, SYSBEL12235, SYSBEL12240, SYSBEL12245, SYSBEL12250, SYSBEL12255, SYSBEL12260, SYSBEL12265, SYSBEL12270, SYSBEL12275, SYSBEL12280, SYSBEL12285, SYSBEL12290, SYSBEL12295, SYSBEL12300, SYSBEL12305, SYSBEL12310, SYSBEL12315, SYSBEL12320, SYSBEL12325, SYSBEL12330, SYSBEL12335, SYSBEL12340, SYSBEL12345, SYSBEL12350, SYSBEL12355, SYSBEL12360, SYSBEL12365, SYSBEL12370, SYSBEL12375, SYSBEL12380, SYSBEL12385, SYSBEL12390, SYSBEL12395, SYSBEL12400, SYSBEL12405, SYSBEL12410, SYSBEL12415, SYSBEL12420, SYSBEL12425, SYSBEL12430, SYSBEL12435, SYSBEL12440, SYSBEL12445, SYSBEL12450, SYSBEL12455, SYSBEL12460, SYSBEL12465, SYSBEL12470, SYSBEL12475, SYSBEL12480, SYSBEL12485, SYSBEL12490, SYSBEL12495, SYSBEL12500, SYSBEL12505, SYSBEL12510, SYSBEL12515, SYSBEL12520, SYSBEL12525, SYSBEL12530, SYSBEL12535, SYSBEL12540, SYSBEL12545, SYSBEL12550, SYSBEL12555, SYSBEL12560, SYSBEL12565, SYSBEL12570, SYSBEL12575, SYSBEL12580, SYSBEL12585, SYSBEL12590, SYSBEL12595, SYSBEL12600, SYSBEL12605, SYSBEL12610, SYSBEL12615, SYSBEL12620, SYSBEL12625, SYSBEL12630, SYSBEL12635, SYSBEL12640, SYSBEL12645, SYSBEL12650, SYSBEL12655, SYSBEL12660, SYSBEL12665, SYSBEL12670, SYSBEL12675, SYSBEL12680, SYSBEL12685, SYSBEL12690, SYSBEL12695, SYSBEL12700, SYSBEL12705, SYSBEL12710, SYSBEL12715, SYSBEL12720, SYSBEL12725, SYSBEL12730, SYSBEL12735, SYSBEL12740, SYSBEL12745, SYSBEL12750, SYSBEL12755, SYSBEL12760, SYSBEL12765, SYSBEL12770, SYSBEL12775, SYSBEL12780, SYSBEL12785, SYSBEL12790, SYSBEL12795, SYSBEL12800, SYSBEL12805, SYSBEL12810, SYSBEL12815, SYSBEL12820, SYSBEL12825, SYSBEL12830, SYSBEL12835, SYSBEL12840, SYSBEL12845, SYSBEL12850, SYSBEL12855, SYSBEL12860, SYSBEL12865, SYSBEL12870, SYSBEL12875, SYSBEL12880, SYSBEL12885, SYSBEL12890, SYSBEL12895, SYSBEL12900, SYSBEL12905, SYSBEL12910, SYSBEL12915, SYSBEL12920, SYSBEL12925, SYSBEL12930, SYSBEL12935, SYSBEL12940, SYSBEL12945, SYSBEL12950, SYSBEL12955, SYSBEL12960, SYSBEL12965, SYSBEL12970, SYSBEL12975, SYSBEL12980, SYSBEL12985, SYSBEL12990, SYSBEL12995, SYSBEL13000, SYSBEL13005, SYSBEL13010, SYSBEL13015, SYSBEL13020, SYSBEL13025, SYSBEL13030, SYSBEL13035, SYSBEL13040, SYSBEL13045, SYSBEL13050, SYSBEL13055, SYSBEL13060, SYSBEL13065, SYSBEL13070, SYSBEL13075, SYSBEL13080, SYSBEL13085, SYSBEL13090, SYSBEL13095, SYSBEL13100, SYSBEL13105, SYSBEL13110, SYSBEL13115, SYSBEL13120, SYSBEL13125, SYSBEL13130, SYSBEL13135, SYSBEL13140, SYSBEL13145, SYSBEL13150, SYSBEL13155, SYSBEL13160, SYSBEL13165, SYSBEL13170, SYSBEL13175, SYSBEL13180, SYSBEL13185, SYSBEL13190, SYSBEL13195, SYSBEL13200, SYSBEL13205, SYSBEL13210, SYSBEL13215, SYSBEL13220, SYSBEL13225, SYSBEL13230, SYSBEL13235, SYSBEL13240, SYSBEL13245, SYSBEL13250, SYSBEL13255, SYSBEL13260, SYSBEL13265, SYSBEL13270, SYSBEL13275, SYSBEL13280, SYSBEL13285, SYSBEL13290, SYSBEL13295, SYSBEL13300, SYSBEL13305, SYSBEL13310, SYSBEL13315, SYSBEL13320, SYSBEL13325, SYSBEL13330, SYSBEL13335, SYSBEL13340, SYSBEL13345, SYSBEL13350, SYSBEL13355, SYSBEL13360, SYSBEL13365, SYSBEL13370, SYSBEL13375, SYSBEL13380, SYSBEL13385, SYSBEL13390, SYSBEL13395, SYSBEL13400, SYSBEL13405, SYSBEL13410, SYSBEL13415, SYSBEL13420, SYSBEL13425, SYSBEL13430, SYSBEL13435, SYSBEL13440, SYSBEL13445, SYSBEL13450, SYSBEL13455, SYSBEL13460, SYSBEL13465, SYSBEL13470, SYSBEL13475, SYSBEL13480, SYSBEL13485, SYSBEL13490, SYSBEL13495, SYSBEL13500, SYSBEL13505, SYSBEL13510, SYSBEL13515, SYSBEL13520, SYSBEL13525, SYSBEL13530, SYSBEL13535, SYSBEL13540, SYSBEL13545, SYSBEL13550, SYSBEL13555, SYSBEL13560, SYSBEL13565, SYSBEL13570, SYSBEL13575, SYSBEL13580, SYSBEL13585, SYSBEL13590, SYSBEL13595, SYSBEL13600, SYSBEL13605, SYSBEL13610, SYSBEL13615, SYSBEL13620, SYSBEL13625, SYSBEL13630, SYSBEL13635, SYSBEL13640, SYSBEL13645, SYSBEL13650, SYSBEL13655, SYSBEL13660, SYSBEL13665, SYSBEL13670, SYSBEL13675, SYSBEL13680, SYSBEL13685, SYSBEL13690, SYSBEL13695, SYSBEL13700, SYSBEL13705, SYSBEL13710, SYSBEL13715, SYSBEL13720, SYSBEL13725, SYSBEL13730, SYSBEL13735, SYSBEL13740, SYSBEL13745, SYSBEL13750, SYSBEL13755, SYSBEL13760, SYSBEL13765, SYSBEL13770, SYSBEL13775, SYSBEL13780, SYSBEL13785, SYSBEL13790, SYSBEL13795, SYSBEL13800, SYSBEL13805, SYSBEL13810, SYSBEL13815, SYSBEL13820, SYSBEL13825, SYSBEL13830, SYSBEL13835, SYSBEL13840, SYSBEL13845, SYSBEL13850, SYSBEL13855, SYSBEL13860, SYSBEL13865, SYSBEL13870, SYSBEL13875, SYSBEL13880, SYSBEL13885, SYSBEL13890, SYSBEL13895, SYSBEL13900, SYSBEL13905, SYSBEL13910, SYSBEL13915, SYSBEL13920, SYSBEL13925, SYSBEL13930, SYSBEL13935, SYSBEL13940, SYSBEL13945, SYSBEL13950, SYSBEL13955, SYSBEL13960, SYSBEL13965, SYSBEL13970, SYSBEL13975, SYSBEL13980, SYSBEL13985, SYSBEL13990, SYSBEL13995, SYSBEL14000, SYSBEL14005, SYSBEL14010, SYSBEL14015, SYSBEL14020, SYSBEL14025, SYSBEL14030, SYSBEL14035, SYSBEL14040, SYSBEL14045, SYSBEL14050, SYSBEL14055, SYSBEL14060, SYSBEL14065, SYSBEL14070, SYSBEL14075, SYSBEL14080, SYSBEL14085, SYSBEL14090, SYSBEL14095, SYSBEL14100, SYSBEL14105, SYSBEL14110, SYSBEL14115, SYSBEL14120, SYSBEL14125, SYSBEL14130, SYSBEL14135, SYSBEL14140, SYSBEL14145, SYSBEL14150, SYSBEL14155, SYSBEL14160, SYSBEL14165, SYSBEL14170, SYSBEL14175, SYSBEL14180, SYSBEL14185, SYSBEL14190, SYSBEL14195, SYSBEL14200, SYSBEL14205, SYSBEL14210, SYSBEL14215, SYSBEL14220, SYSBEL14225, SYSBEL14230, SYSBEL14235, SYSBEL14240, SYSBEL14245, SYSBEL14250, SYSBEL14255, SYSBEL14260, SYSBEL14265, SYSBEL14270, SYSBEL14275, SYSBEL14280, SYSBEL14285, SYSBEL14290, SYSBEL14295, SYSBEL14300, SYSBEL14305, SYSBEL14310, SYSBEL14315, SYSBEL14320, SYSBEL14325, SYSBEL14330, SYSBEL14335, SYSBEL14340, SYSBEL14345, SYSBEL14350, SYSBEL14355, SYSBEL14360, SYSBEL14365, SYSBEL14370, SYSBEL14375, SYSBEL14380, SYSBEL14385, SYSBEL14390, SYSBEL14395, SYSBEL14400, SYSBEL14405, SYSBEL14410, SYSBEL14415, SYSBEL14420, SYSBEL14425, SYSBEL14430, SYSBEL14435, SYSBEL14440, SYSBEL14445, SYSBEL14450, SYSBEL14455, SYSBEL14460, SYSBEL14465, SYSBEL14470, SYSBEL14475, SYSBEL14480, SYSBEL14485, SYSBEL14490, SYSBEL14495, SYSBEL14500, SYSBEL14505, SYSBEL14510, SYSBEL14515, SYSBEL14520, SYSBEL14525, SYSBEL14530, SYSBEL14535, SYSBEL14540, SYSBEL14545, SYSBEL14550, SYSBEL14555, SYSBEL14560, SYSBEL14565, SYSBEL14570, SYSBEL14575, SYSBEL14580, SYSBEL14585, SYSBEL14590, SYSBEL14595, SYSBEL14600, SYSBEL14605, SYSBEL14610, SYSBEL14615, SYSBEL14620, SYSBEL14625, SYSBEL14630, SYSBEL14635, SYSBEL14640, SYSBEL14645, SYSBEL14650, SYSBEL14655, SYSBEL14660, SYSBEL14665, SYSBEL14670, SYSBEL14675, SYSBEL14680, SYSBEL14685, SYSBEL14690, SYSBEL14695, SYSBEL14700, SYSBEL14705, SYSBEL14710, SYSBEL14715, SYSBEL14720, SYSBEL14725, SYSBEL14730, SYSBEL14735, SYSBEL14740, SYSBEL14745, SYSBEL14750, SYSBEL14755, SYSBEL14760, SYSBEL14765, SYSBEL14770, SYSBEL14775, SYSBEL14780, SYSBEL14785, SYSBEL14790, SYSBEL14795, SYSBEL14800, SYSBEL14805, SYSBEL14810, SYSBEL14815, SYSBEL14820, SYSBEL14825, SYSBEL14830, SYSBEL14835, SYSBEL14840, SYSBEL14845, SYSBEL14850, SYSBEL14855, SYSBEL14860, SYSBEL14865, SYSBEL14870, SYSBEL14875, SYSBEL14880, SYSBEL14885, SYSBEL14890, SYSBEL14895, SYSBEL14900, SYSBEL14905, SYSBEL14910, SYSBEL14915, SYSBEL14920, SYSBEL14925, SYSBEL14930, SYSBEL14935, SYSBEL14940, SYSBEL14945, SYSBEL14950, SYSBEL14955, SYSBEL14960, SYSBEL14965, SYSBEL14970, SYSBEL14975, SYSBEL14980, SYSBEL14985, SYSBEL14990, SYSBEL14995, SYSBEL15000, SYSBEL15005, SYSBEL15010, SYSBEL15015, SYSBEL15020, SYSBEL15025, SYSBEL15030, SYSBEL15035, SYSBEL15040, SYSBEL15045, SYSBEL15050, SYSBEL15055, SYSBEL15060, SYSBEL15065, SYSBEL15070, SYSBEL15075, SYSBEL15080, SYSBEL15085, SYSBEL15090, SYSBEL15095, SYSBEL15100, SYSBEL15105, SYSBEL15110, SYSBEL15115, SYSBEL15120, SYSBEL15125, SYSBEL15130, SYSBEL15135, SYSBEL15140, SYSBEL15145, SYSBEL15150, SYSBEL15155, SYSBEL15160, SYSBEL15165, SYSBEL15170, SYSBEL15175, SYSBEL15180, SYSBEL15185, SYSBEL15190, SYSBEL15195, SYSBEL15200, SYSBEL15205, SYSBEL15210, SYSBEL15215, SYSBEL15220, SYSBEL15225, SYSBEL15230, SYSBEL15235, SYSBEL15240, SYSBEL15245, SYSBEL15250, SYSBEL15255, SYSBEL15260, SYSBEL15265, SYSBEL15270, SYSBEL15275, SYSBEL15280, SYSBEL15285, SYSBEL15290, SYSBEL15295, SYSBEL15300, SYSBEL15305, SYSBEL15310, SYSBEL15315, SYSBEL15320, SYSBEL15325, SYSBEL15330, SYSBEL15335, SYSBEL15340, SYSBEL15345, SYSBEL15350, SYSBEL15355, SYSBEL15360, SYSBEL15365, SYSBEL15370, SYSBEL15375, SYSBEL15380, SYSBEL15385, SYSBEL15390, SYSBEL15395, SYSBEL15400, SYSBEL15405, SYSBEL15410, SYSBEL15415, SYSBEL15420, SYSBEL15425, SYSBEL15430, SYSBEL15435, SYSBEL15440, SYSBEL15445, SYSBEL15450, SYSBEL15455, SYSBEL15460, SYSBEL15465, SYSBEL15470, SYSBEL15475, SYSBEL15480, SYSBEL15485, SYSBEL15490, SYSBEL15495, SYSBEL15500, SYSBEL15505, SYSBEL15510, SYSBEL15515, SYSBEL15520, SYSBEL15525, SYSBEL15530, SYSBEL15535, SYSBEL15540, SYSBEL15545, SYSBEL15550, SYSBEL15555, SYSBEL15560, SYSBEL15565, SYSBEL15570, SYSBEL1

Drench Hose

Drench hose units, WG7011R & WG7012R are for deck mounting. Ideal for rinsing any part of user's eye, face or body. Under ANSI Z358.1-2014, drench hose units supplement, but do not replace, other types of emergency equipment.

- To meet the standard of Emergency Eyewash and Shower Equipment in ANSI Z358.1-2014 and AS4775-2007;
- Single or double spray head is optional, which has dust cover;
- Forged brass squeeze valve activated by plastic lever handle. Valve has replaceable stainless steel seat for exceptional durability. Valve closes when lever handle is released.
- 1.5m soft PVC tube wrapped by PE film relief from rust and leakage, and internal filter to remove impurities from the water flow.
- Spray heads provide even, continued and comfortable fluid to irrigate the eye;
- Eye wash exceeds minimum water flow of 0.4GPM(1.5LPM) at 210kPa (30psi);
- Deck flange for countertop mounting, flange has a position to fix the unit.



WG7011R



WG7012R

Drench Hose

Product	Main Material	Color	Flow Speed (L/min)	Inlet & Outlet	Pressure (bar)	Packing size L*W*H/cm	Model
Drench Hose (Single)	304SS	Red	6	G1/2"	3-6	27.4×19.6×15.6	WG7011R
Drench Hose (Double)	304SS	Red	10	G1/2"	3-6	27.4×19.6×15.6	WG7012R

Wall Mounted Eye/Face Wash

- Application:Eye/Face wash for wall mounting. The bowl guides waste water to drain and keeps floor clean
- Materials: AES plastic + 304 Stainless Steel
- AES plastic has weather resistance properties and applies to indoors or outdoors
- With good acid-proof,alkali prevention performances,304SS is ideal for harsh environment
- Activated by push handle easily
- The coin slot hidden faucet aerator is easy to remove and clean
- Dust cover is removed once unit started
- Comply with ANSI Z358.1-2014 and AS 4775-2007



WG7023



WG7023Y



WG7023G



WG7033F



WG7033FY



WG7033FG

Pedestal Mounted Eye/Face Wash

- Application:Free standing, fixed on the ground when it is not convenient for wall-mounting
- Materials: AES plastic + 304 Stainless Steel
- AES plastic has weather resistance properties and applies to indoors or outdoors
- With good acidproof ,alkali prevention performances,304SS is ideal for harsh environment
- Be activated by push handle or foot pedal easily
- The coin slot hidden faucet aerator is easy to remove and clean
- Dust cover is removed once unit started
- Comply with ANSI Z358.1-2014 and AS 4775-2007

Eye/Face Wash

Product	Main Material	Water Bowl		Flow Rate (L/min)	Inlet	Outlet	Pressure	Packing size LxWxH(cm)	Certification	Model
		Material	Diameter x Height (cm)							
Wall Mounted Eye/Face Wash	304 Stainless Steel	304 Stainless Steel	32×9.5	11.4	1/2"	1-1/4"	210kPa or 2.1bar or 30psi	58×36×25.5	ANSI Z358.1 AS 4775 CSA CE	WG7023
		AES plastic								WG7023Y
		304 Stainless Steel								WG7023G
Pedestal Mounted Eye/Face Wash	304 Stainless Steel	304 Stainless Steel	32×9.5	11.4	1/2"	1"	210kPa or 2.1bar or 30psi	95×35×26.5	ANSI Z358.1 AS 4775 CSA CE	WG7033F
		AES plastic								WG7033FY
		304 Stainless Steel								WG7033FG

Portable Eyewash

Portable Eye Wash Station

- It adopts PE materials, and the production materials comply with the regulations of F.D.A on the grade on PE materials for food (F.D.A. Regulation on Polypropylene: the requirements of U.S.21 CFR F.D.A. Regulation Part 177.1520, portable containers clauses (C) for food contact use),and it is superior in its high intensity, good toughness, good Rigidity, heat and cold resistance
- It complies with human engineering principle in design, and adopts the law of gravity to produce water pressure and deliver water to two nozzles for eye washing
- It applies to work places without water supply and discharge facilities and can be installed and fixed onto walls as required to provide timely and professional protection
- It complies with regulations of ANSI/ISEA on emergency eye wash station and showering equipment-ANSI Z358.1-2014
- It is suggested to discharge the liquid in eye wash station every two or four weeks or as required and clean every component of eye wash station



WG6000B

WG6000A

Portable Eye Wash Station

Type	Main Material	Water Capacity (L/Gal)	Flow Speed (L/min)	Flushing Time(min)	Ext. size HxWxD(mm)	Packing size HxWxD(mm)	Certification	Model
Type A	PE	60/16	2.6	18	735x420x416	436x750x435	ANSI Z358.1 AS 4775 CE	WG6000A
Type B		30/8	2.6	9	625x350x342	357x635x360		WG6000B

Portable Eyewash with Mobile Waste Cart

- Mobile waste cart adds portability and even holds the unit, also, collects waste water
- Perfectly equipped with WG6000A and WG6000B
- After placing on the cart, the spray heads are located between 83.8-134.6cm from the floor, which comply with ANSI Z358.1-2014
- Highly visible yellow, rugged polyethylene construction is well suited to long term use in harsh environments
- Built in handle for easy transport is great for use on remote site
- Petcock on the bottom for easy drainage
- Comes equipped with two rigid casters in front and two swivel casters with "Total Lock" brakes in back
- Includes clearly marked eyewash signs
- Cart has 37.5-gallon (142 liter) capacity and measures 86H x61.5W x 52D (cm)



WG6000AD



WG6000BD



WG005

Portable Eyewash with Mobile Waste Cart

Main Material	Water Capacity(L/Gal)	Flow Speed(L/min)	Flushing Time (min)	Product Mix	Certification	Model
Poplyethylene	60/16	2.6	18	WG6000A+WG005	ANSI Z358.1 AS 4775 CE	WG6000AD
Poplyethylene	30/8	2.6	9	WG6000B+WG005		WG6000BD

Mobile Waste Cart

Material	Capacity(Gal/L)	Ext.size(mm)H*W*D	Packing size(mm)H*W*D	Model
Poplyethylene	37.5/142	860×615×520	760×629×535	WG005

Cable Heating Emergency Shower

Cable Heating Emergency Shower and Eyewash is the indoor/outdoor anti-freezing equipment with emergency rescue and primary processing. The unit can be used in -50°C. It is consist of 304SS main pipe, heating cable, temperature controller, air safety layer, outer insulation layer and 304SS shell. Cable Heating Emergency Shower and Eyewash are manufactured ad per standard CE-DIN12899-UN19608. When the chemicals or toxic substances splash to the staff body, face, eye or fire to staff clothing. The unit can quickly bring harm to a minimum. The soft rubber protecting cup can avoid second hurt resulted by colliding eyes when use it urgently. Standards Licensed to the internationally recognised standard ANSI Z358.1-2014 and are compliant with AS4775-2007 for Emergency Eyewash and Shower equipment.

Cable Heating Emergency Shower

Main Material	Color	Flow Speed (L/min)	Inlet	Outlet	Pressure (bar)	Packing size L*W*H/cm	Model
304SS	Red	Eye: 10L/min Shower: 80L/min	from 1" to 1/2"	1"	3-6bar	230×70×30	WG7054ER



Emergency Shower Room

Emergency Shower Rooms are manufactured as per standard CE-DIN12899-UN19608. When the chemicals or toxic substances splash to the staff body, face, eye or fire to staff clothing. The unit can quickly bring harm to a minimum. The soft rubber protecting cup can avoid second hurt resulted by colliding eyes when use it urgently. Standards Licensed to the internationally recognised standard ANSI Z358.1-2014 and are compliant with AS4775-2007 for Emergency Eyewash and Shower equipment.

Emergency Shower Room

Main Material	Color	Flow Speed (L/min)	Inlet	Pressure (bar)	Packing size L*W*H/cm	Model
304SS	Silver	Eye: 10L/min Shower: 80L/min	from 1" to 1/2"	3-6bar	240×130×45	WG7054H



Wash Sink

1. Applicable environment: It can be used for eye and face washing. All floor drains and drainage facilities in the installation site are required to be dredged and flushed in time;
2. Sink and faucet are highly ergonomic and easy to use;
3. The internal connecting water pipes are all hose connections, and the connection joints with the water inlet pipe and the drain pipe are standard parts;
4. Water pressure used: not less than 210kpa (30psi, 2bar, 2.1kgf/cm² Kg / cm²);
5. Water output: higher than the standard requirement of 1.5lpm (0.4gpm).



WG70301



WG70302

Wash Sink

Material	Product Name	Capacity	water intake	Recommended water pressure / kpa	External dimension L*W*H/cm	Package dimension L*W*H/cm	Model
304 stainless steel	Portable Sink	20L	-	-	50x50x80	55x55x95	WG70301
	Eye Wash Sink	-	G1/2	210			WG70302

Wall Mounted First Aid Kit

- 1)The internal compartment is convenient for user to find drugs.
- 2)It is made of steel, and powder-coat provides excellent chemical resistance.
- 3)There is handle for hand-carry conveniently, also can be fixed on the wall with screws.
- 4)Safety lock catch can make the door close tightly, avoid the dropping of drugs.



WGA0201W



WGA0202W

Instruction

- 1)Put drugs on the internal compartments.
- 2)If you want to hang the first aid kit on the wall, you can fix it on the wall with screws, there are two holes on the back of first aid kit for screws .
- 3)Close the lock immediately after using the medicine to avoid drugs falling down.

Attention

- 1)Please do not expose the first aid kit to the sunlight and high temperature environment, avoid drug deterioration.
- 2)After the use of drugs that are prone to dampness, close the door timely. If the drugs have been dampened, they should be cleaned timely to avoid cross-contamination.
- 3)The first aid kit should be placed in a fixed and conspicuous and convenient position to ensure that it is immediately available when needed.
- 4)Replenish drugs in time for a rainy day.
- 5)Disposal of expired drugs in time.



Supplementary Set WGA0201W-1

2 rolls spandex plain white bandage (75g), 1 piece emergency blanket, 1 piece triangle bandage 90cm×90cm×130cm, 2 pieces burn dressing, 4 pieces medical gauze block (10cm×10cm) 8 layers, 10 pieces safety pin, 1 pair Tweezer, 10 pieces disposable disinfection tablet, 1 roll Medical tape, 2 pieces clip-on tourniquet, 1 pair emergency scissor, 1 piece polymer emergency splint, 1 piece first aid flashlight, 1 copy first aid instruction, 1 copy first aid manual, 1 piece first aid whistle, 1 bag Iodophor cotton swabs (12 pcs / pack), 2 pieces 0.9% saline solution (15ml), 1 piece disposable artificial respiration membrane (CPR), 1 piece PE valve bag, 1 piece office first aid box (empty box)

壁掛式金屬急救箱

材質	外形尺寸 (长×宽×高/cm)	包裝尺寸 (长×宽×高/cm)	攜帶方式	型号
鋼	40×26×11.5	43×29×15	壁掛 / 手提	WGA0201W
鋼	40×26×11.5	43×29×15	壁掛 / 手提	WGA0202W

New!

New!



CE certification

Goggles Products



Multiple protections for multiple scenarios

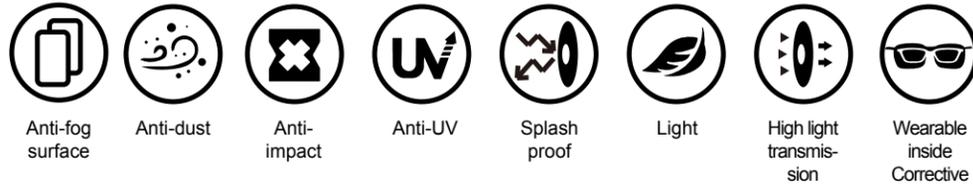

Safety Goggles

Used to prevent the impact of high-speed particles. The anti-fog and ultraviolet-proof characteristics help to reduce the risk of fog and to ensure eye safety.



WG-7228

WG-7280

WG-7253

WG-7256

Safety Goggles								
Certification	Color of optic-catio	Optic material-catio	Antifo-gging	Ultraviolet-proo	Heated temperature	leg of glasses	Features	Model
CE	Transparent	PC	✓	✓	~5-55	4-direction flection	4-direction flection Adjustment leg of glasses and bayonet design	WG-7228
			✓	✓	~5-55	Assembled frame, Lateral wing, eyebrow, and guard frame are in the integration	Assembled frame. Lateral wing, eyebrow, and guard frame are in the integration. Optic and frame are designed integrally. It has ventilated lateral wing and no metal accessories. Corrective glasses can be wore inside and it can be used as visiting glasses.	WG-7280
			✓	✓	~5-55	A soft leg of glasses that can rotate up and down.	Soft leg of glasses, 3-direction flection. Adjustment leg of glasses and bayonet design. Unique soft nose beam support.	WG-7253
			✓	✓	~5-55	A soft leg of glasses. 3-directions flection that can rotate leg of glasses. 3-directions flection that can rotate leg of glasses.	A soft leg of glasses and unique soft nose beam support.	WG-7256

Safety Eyeshield

To prevent from the splashing of chemical liquid. The frame adopts indirect vent design to effectively reduce dust entry and ensure eye safety.



WG-9200

WG-9201

Safety Eyeshield								
Certifi-cation	Color of optic-catio	Optic material-catio	Antifo-gging	Ultraviolet-proo	Heated temperature	leg of glasses	Features	Model
CE	Transparent	PC	✓	✓	~5-55	N/A	Fit closely with face. Anti-chemical, impact-resistant and corrective glasses can be wore inside.	WG-9200
			✓	✓	~5-55	N/A		WG-9201

Face Shield

The Face Shield can provide protection for the face and prevent injuries caused by the splash of liquid, spray, dust and particles. It is suitable for disease control and epidemic prevention, dentistry, stomatology equipment cleaning, decoration cleaning, chemical production, and practitioners who need face protection, eye protection, nose and mouth protection.



Product Features:

- (1).The shield is made of double-sided anti-fog PET material, colorless and transparent, high light transmission, and long-lasting anti-fog aging.
- (2).Large-scale isolation protection close to 180 °, full face protection against liquid and spray.
- (3).The face shield is light and thin, and has an elastic structure composed of a skin-friendly sponge and a highly elastic stretch band, which is no longer heavy and comfortable to wear.
- (4).The product has the CE certification of the EU Notified Body.

Face Shield				
Certification	Packing quantity (PCS/ carton)	Ext dimension (H*W*D/cm)	Packing dimension (H*W*D/cm)	Model
CE	200 / carton	33*22*3	64*35*38	WG-8100

Notice

- (1).Please tear off the surface film of the shield before use.
- (2).Avoid storage in direct sunlight.
- (3).If it is used in medical and health occasions, it is recommended for one-time use.

Total Solution of Chemical Management in Industry

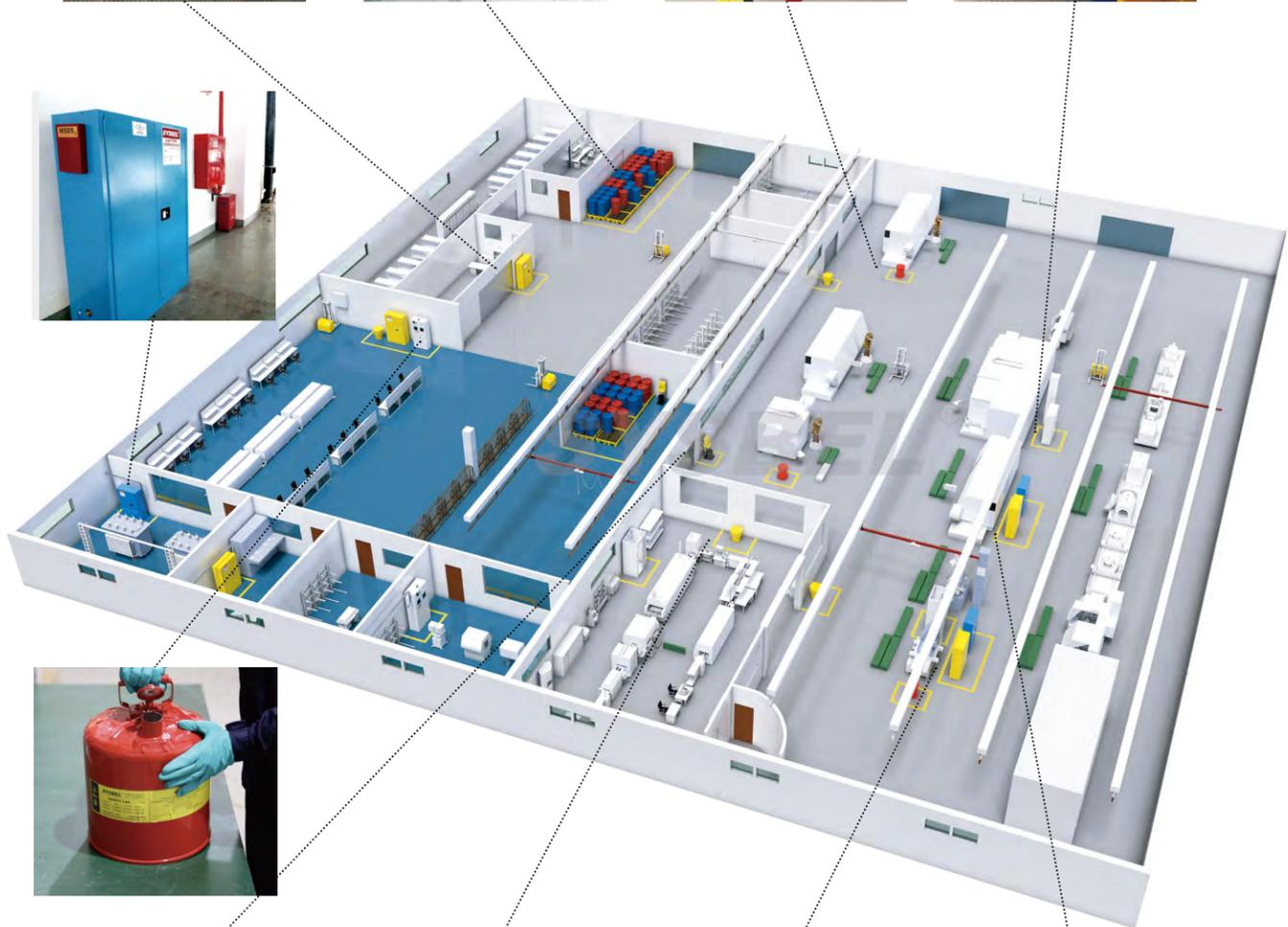

* Please contact SYSBEL for more solutions

Total Solution of the Lab Industry



* Please contact SYSBEL for more solutions

Safety Cabinet Size Chart

Types of Safety Cabinet	Color Classification	Capacity (Gal)	Capacity (L)	Overall Capacity HxWxD(cm)	Internal dimensions HxWxD(cm)	Number of Standard Shelf	Hook spacing (cm)
WA810040 / WA810041 / WA810040R / WA810040B	Yellow, Yellow, Red, Blue	4	15	56x43x43	46x35x35	1	/
WA810100	Yellow	10	38	64x59x60	54x51x52	1	/
WA810120 / WA810121 / WA810122 / WA810120R / WA810120B / WA810120W / WA810122W / WA810120G	Yellow, Yellow, Yellow, Red, Blue, White, White, Green	12	45	89x59x46	79x51x38	1	7.6
WA3810120	Yellow	12	45	46x109x46	36x101x38	-	7.6
WA3810170 / WA810170	Yellow, Yellow,	17	64	61x109x46	51x101x38	1	7.6
WA0810190	Yellow	19	72	91x76x57	81x67x46	1	7.6
WA810220 / WA810221 / WA810220B	Yellow, Yellow, Blue	22	83	165x60x46	154x52x38	3	7.6
WA0810230	Yellow	23	87	89x89x55	79x80x48	1	7.6
WA810300 / WA810301 / WA810300R / WA810300B / WA810300W / WA810303	Yellow, Yellow, Red, Blue, Blue	30	114	112x109x46	102x101x38	1	7.6
WA810300C	Yellow	30	114	112x109x46	102x102x47	1	7.6
WA810450 / WA810451 / WA810452 / WA810450R / WA810450B / WA810450W / WA810452W / WA810450G / WA810453	Yellow, Yellow, Yellow, Red, Blue, White, White, Green, Blue	45	170	165x109x46	155x101x38	2	7.6
WA810540 / WA810541	Yellow, Yellow	54	204	165x60x87	155x52x79	3	7.6
WA810550	Yellow	55	207	165x86x86	155x78x78	1	7.6
WA810600 / WA810601 / WA810600R / WA810600B	Yellow, Yellow, Red, Blue	60	227	165x86x86	155x78x78	2	7.6
WA810860 / WA810861 / WA810860R / WA810860B	Yellow, Yellow, Red, Blue	90	340	165x109x86	155x101x78	2	7.6
WA811100	Yellow	110	415	165x150x86	155x142x78	1	7.6
WA810115	Yellow	115	434	165x150x86	155x142x78	2	7.6
ACP810004	White Polypropylene	4	15	59x46x43	55x44x36	1	8
ACP810012	White Polypropylene	12	45	89x59x46	82x57x39	1	8
ACP810024	White Polypropylene	24	90	89x59x46	82x57x39	1	8
ACP810030	White Polypropylene	30	114	112x109x46	105x107x39	1	8
ACP810048	White Polypropylene	48	180	180x109x46	Upper: 81x107x42 Lower: 83x107x42	2	8
ACP810001	Polypropylene	4	15	49x41x36	44x39.5x30.5	1	-
ACP810002	Polypropylene	22	83	89x90.5x54.5	76x89x49.5	4	-

SYSBEL Eye Wash Station Selection Guide

Eye Wash Type	Material	ANSI Standard Speed (L/Minute)	Main Character	Type	Use Under Environment				
					Workplace without water supply	Workshop /Lab	Workplace that eye wash can't fix on the wall	Eye and face wash	Eye/face and body wash
Portable Eye Wash Station	Polyethylene	1.5	Only have eye wash nozzle, suitable for outdoor or workplace without water supply.No installation requirements. With the cart which is convenient to move. It can be fixed on the wall according to different requirements	Portable	✓			✓	
Wall Mounted Eyewash(No Bowl)	Stainless Steel	11.4	Only have eye wash nozzle;it will be fixed on the wall so that the space will be saved.	Static		✓		✓	
Wall Mounted Eyewash (With Bowl)	Stainless Steel	11.4	With eye wash nozzle and shower system; Eye wash is used for cleaning chemical spray on the eyes/face; Shower is used for cleaning chemical spray on the body.	Static		✓	✓	✓	
Combination Units (With Bowl)	Stainless Steel	11.4 eyewash 75.6 shower	With eye wash nozzle and shower system; Eye wash is used for cleaning chemical spray on the eyes/face; Shower is used for cleaning chemical spray on the body.	Static		✓	✓	✓	✓
Eyewash Drench Wash	PE, STEEL, COPPER	11.4	Eyewash Drench Wash: suitable for indoor tank water pipe connection for easy extraction and flexible use	Static		✓	✓	✓	✓

Note:

- 1.SYSBEL supply eye wash station & combination drench shower and eye wash, both of which are in accordance with American national standards institute/industrial safety equipment association about the provisions of the emergency eye wash and shower equipment ANSI Z358.1-2014
- 2.Eyewash system includes 5 models: 4 model of portable eyewash, 3 model of wall mounted eye wash, 2 model of pedestal mounted eye wash, 4 model of Combination Units, 6 model of Emergency Showers
- 3.The eye wash models are as below:
 Portable Eye Wash : WG6000A, WG6000B, WG6000D, WG6000BD
 Wall Mounted Eyewash : WG7023, WG7023Y, WG7023G
 Pedestal Mounted Eyewash : WG7033F, WG7033FY, WG7033FG
 Combination Units: WG7053F, WG7053FY, WG7023FG
 Drench Hose : WG7011R, WG7012R

4.Under environment of high acid degree, it is suggested to use eye wash with 304 stainless steel or above level.



SYSBEL Absorbent Material Selection Guide

Disclaimer: The following information is only as a guide, it does not guarantee the absolute accuracy. All the data are based on ambient temperature and pressure, the chemical substance is under the norm circumstances, rather than a mixture or combination. We recommend you to conduct a small test prior to the application of SYSBEL adsorbent materials about their pending chemical compatibility and absorption effect, to ensure application security.
Waste Disposal: Unused polypropylene adsorbent material can be regarded as a common waste disposal in landfills. Cotton pollutants after adsorption of chemical liquid or hazardous materials shall be properly transferred to a chemical disposal bag or bucket with SYSBEL spill response package. They should be transferred to a professional waste disposal organization according to local regulations.

Chemicals	Oil Only Polypropylene	Universal and Hazmat Polypropylene
Acetaldehyde		*
Acetic Acid	*	
Acetic Anhydride		*
Acetone	*	*
Acetyl Bromide	*	*
Acetyl Chloride	*	*
Acrolein	*	*
Acrylonitrile		*
Acrylic Acid		*
Acrylic Emulsions		*
Allyl Alcohol		*
Allyl Chloride	*	
Aluminum Hydroxide		*
Aminobenzoic Acid		*
Ammonia (Anhydrous)	*	*
Ammonium Hydroxide	*	*
Amyl Acetate	*	*
Amyl Alcohol	*	*
Aniline		*
Aqua Regia		*
Arsenic Trichloride		*
Aviation Fuel	*	*
Barium Hydroxide		*
Benzene	*	*
Benzoic Acid	*	*
Benzonitrile		*
Benzol Chloride		*
Benzyl Chloride	*	*
Benzyl Alcohol	*	*
Boric Acid	*	*
Brake Fluid	*	*
Bromine		*
Butyl Acetate	*	*
Butyl Alcohol	*	*
Butyl Phthalate	*	*
Butyric Acid	*	*
Butylamine	*	*
Butyric Acid	*	*
Calcium Hydroxide	*	*
Calcium Hypochlorite	*	*
Carbolic Acid	*	*
Carbon Disulfide	*	*
Carbon Tetrachloride	*	*
Castor Oil	*	*
Chlorine Water	*	*
Chloroacetic Acid	*	*
Chlorobenzene	*	*
Chlordane	*	*
Chloroform	*	*
Chromic Acid (50%)	*	*
Chlorosulfonic Acid	*	*
Citric Acid	*	*
Clorox (Full Strength Bleach)	*	*
Corn Oil	*	*
Cottonseed Oil	*	*
Cresol	*	*
Cyclohexane	*	*
Detergents	*	*
Diazinon	*	*
Dichlorobenzene	*	*
Dichloropropane	*	*
Dichloropropene	*	*
Diethylamine	*	*
Diethyl Ether	*	*
Disooctyl Phthalate	*	*
Disulfoton	*	*
Dinitrobenzene	*	*
Dioxan	*	*
Ehtion	*	*
Epichlorohydrin	*	*
Ether	*	*
Ethyl Acetate	*	*
Ethyl Alcohol	*	*
Ethyl Benzene	*	*
Ethyl Chloride	*	*
Ethyl Ether	*	*
Ethyl Propionate	*	*
Ethylene Dibromide	*	*
Ethylene Dichloride	*	*
Ethylene Glycol	*	*
Ethylenediamine	*	*
Formaldehyde	*	*
Formic Acid	*	*
Fuel Oil	*	*
Furfural	*	*
Gasoline	*	*
Gearbox Oil	*	*
Glacial Acetic Acid	*	*
Glycerol	*	*

Chemicals	Oil Only Polypropylene	Universal and Hazmat Polypropylene
Heptane	*	*
Hexane	*	*
Hydrazine	*	*
Hydrochloric Acid	*	*
Hydrofluoric Acid	*	*
Hydrogen Cyanide	*	*
Hydrogen Peroxide	*	*
Isobutyl Alcohol	*	*
Isobutyric Acid	*	*
Isoprene	*	*
Isopropyl Acetate	*	*
Isopropyl Alcohol	*	*
Kerosene	*	*
Keytones	*	*
Linseed Oil	*	*
Lubricating Oil	*	*
Magnesium Hydroxide	*	*
Malathion	*	*
Methyl Alcohol	*	*
Methyl Chloride	*	*
Methyl Ether	*	*
Methyl Ethyl Ketone	*	*
Methyl Methacrylate	*	*
Methyl Propionate	*	*
Mevinphos	*	*
Mineral Oil	*	*
Monoethylamine	*	*
Monomethylamine	*	*
Motor Oil	*	*
Naphthalene	*	*
Nitric Acid	*	*
Nitrobenzene	*	*
Nitrobenzoic Acid	*	*
Nitrotoluene	*	*
Octane	*	*
Oleic Acid	*	*
Olive Oil	*	*
Paraffin	*	*
Parathion	*	*
Perchloroethylene	*	*
Petroleum Ether	*	*
Phenol	*	*
Phosphorous Oxychloride	*	*
Phosphorous Trichloride	*	*
Phosphoric Acid	*	*
Plating Solutions	*	*
Polychlorinated Biphenyls	*	*
Potassium Hydroxide	*	*
Propanol	*	*
Propionic Acid	*	*
Propionic Anhydride	*	*
Propyl Alcohol	*	*
Propylene Glycol	*	*
Propylene Oxide	*	*
Pyrethrins	*	*
Quinoline	*	*
Resorcinol	*	*
Salt Solutions (Metallic)	*	*
Silicone Oil	*	*
Silver Nitrate	*	*
Soap Solution (Concentrated)	*	*
Sodium Bicarbonate	*	*
Sodium Chloride	*	*
Sodium Hydroxide	*	*
Sodium Hypochlorite	*	*
Sodium Nitrate	*	*
Stannic Chloride	*	*
Starch	*	*
Styrene	*	*
Sucrose	*	*
Sulfur Monochloride	*	*
Sulfuric Acid	*	*
Synthetic Motor Oil	*	*
Tannic Acid	*	*
Tetraethyllead	*	*
Tetraethylpyrophosphate	*	*
Toluene	*	*
Transformer Oil	*	*
Trichloroethylene	*	*
Triethylamine	*	*
Triethylene Glycol	*	*
Trimethylamine	*	*
Turpentine	*	*
Urine	*	*
Vinyl Acetate	*	*
Vinegar	*	*
Vinylidene Chloride	*	*
Xylene	*	*

User's Guide for SYSBEL Polyethylene Products

Substance	Concentration	Character
Acetic acid, Glacial	100°C	strongly corrosive, flammable
Acetic acid, aqueous	80°C	strongly corrosive, flammable
Acetic acid, aqueous	70°C	corrosive, flammable
Acetic acid, aqueous	30-60°C	corrosive, flammable
Acetic acid, aqueous	20-30°C	corrosive, flammable
Acetic acid, aqueous	10-20°C	corrosive, flammable
Acetic acid, aqueous	0-10°C	corrosive
Acetic acid+acetic acid	90 : 10	corrosive, flammable, toxic
Acetic anhydride		corrosive, flammable
Adipic Acid		corrosive, combustible
Acids, aromatic		corrosive
Aluminum chloride, anhydrous	any	corrosive, irritant
Ammonium sulphide, aqueous	any	corrosive, flammable
Aqua regia (HCl+HNO3)		strongly corrosive
Battery fluid, acid		corrosive
Benzene sulphonic acid		corrosive, irritant
Bromic acid	conc.	corrosive, irritant
Bromine(liquid)		corrosive, toxic
Butyric acid	any	corrosive
Carbolic acid		corrosive, combustible
Chloroacetic acid, aqueous	≤ 85%	corrosive, combustible
Chloric Acid 20% 20%	20%	strong acid, corrosive
Chlorine water 2%	2%	corrosive, irritant
Chlorine Water Saturated	Saturated	corrosive, irritant
Chloroform		very humful, toxic
Carbolium	as supplied commerc.	corrosive
Chlorosulphonic acid	techn. grade	corrosive, irritant
Chromic acid		corrosive
Chlorine, liquid		toxic, corrosive, flammable, irritant
Citric Acid		corrosive, combustible
Cresylic Acid		toxic, corrosive
Diglycolic Acid, aqueous		irritant
Decahydronaphthalene(Dekalin)		humful, corrosive
Ethylenediamine	techn. grade	humful, corrosive, flammable
1, 2-Dibromoethane 1,2		toxic
Dibutyl ether		irritant, flammable
Dextrin		
Dextrose		
Dichloromethane		humful, irritant
Dichloropropene		flammable
Dichloroacetic acid	techn. grade	corrosive, toxic
Dichloroacetic acid	50%	corrosive, toxic
Dichloroacetic acid methyl ester		irritant, combustible
Ethylenediamine tetraacetic acid		irritant, combustible
Ethyl acetate (acetic acid ethyl ester)		flammable, toxic
Fatty acids(> C6)		
Fluoroboric Acid		corrosive, irritant
Fluorosilicic Acid		corrosive, toxic
Foric Acid		corrosive
Formic acid, aqueous	10%	corrosive
Formic acid, aqueous	25%	corrosive
Formic acid, aqueous	50%	corrosive, combustible
Formic acid, aqueous	100%	corrosive, combustible
Gallic Acid		irritant
Glacial acetic acid(100% acetic acid)		strongly corrosive, flammable
Glycolic Acid	30%	corrosive
Glycolic Acid	up to 70%	corrosive
Hydrobromic Acid	20%	corrosive, irritant
HCl(hydrochloric acid)	10%	corrosive
HCl(hydrochloric acid)	48%	corrosive
HCl(hydrochloric acid)	any	corrosive
Hydrofluoric Acid	4%	corrosive
Hydrofluoric Acid	10%	corrosive
Hydrofluoric Acid	48%	corrosive
Hydrofluoric Acid	60%	corrosive
Hydrofluorosilic Acid		corrosive
HNO3(nitric acid)	25%	strong acid, corrosive
HNO3(nitric acid)	50%	strong acid, corrosive
HNO3(nitric acid)	95%	strong acid, corrosive
HClO4(perchloric acid)	20%	strong acid, corrosive

Substance	Concentration	Character
HClO4(perchloric acid)	50%	strong acid, corrosive
HClO4(perchloric acid)	70%	strong acid, corrosive
H2SO4(sulfuric acid)	up to 50%	strong acid, corrosive
H2SO4(sulfuric acid)	70%	strong acid, corrosive
H2SO4(sulfuric acid)	80%	strong acid, corrosive
H2SO4(sulfuric acid)	98%	strong acid, corrosive
Hydrogen peroxide, aqueous	10%	humful, corrosive
Hydrogen peroxide, aqueous	30%	humful, corrosive
Hydrogen peroxide, aqueous	100%	humful, corrosive
Hypochlorous acid		corrosive, irritant
Isobutyric acid		corrosive, humful, flammable
Lactic acid, aqueous DL		corrosive, irritant
Maleic Acid, Aqueous	up to 100%	humful
Malic acid, aqueous	50%	irritant, combustible
Methacrylic acid		flammable, corrosive
Methyl Acetate		flammable, irritant
Nicotine Acid		irritant
Oleic Acid		irritant, combustible
Oleum		corrosive
Oxalic Acid		corrosive, combustible
Palmitic acid		irritant
Perchloric acid	10%	corrosive, irritant
Perchloric acid	70%	corrosive, irritant
Peracetic Acid	40%	corrosive, flammable
Phosphoric Acid	0-25%	corrosive
Phosphoric Acid	25-50%	corrosive
Phosphoric Acid	50-90%	corrosive
Picric Acid		flammable, toxic
Salicylic Acid		humful
Selenic acid		corrosive, toxic
Silicic Acid		corrosive, irritant
Silicone fluids		irritant, combustible
Stearic acid		irritant
Sulphurous acid		corrosive, combustible
Succinic acid, aqueous	50%	corrosive, combustible
Tannic acid		irritant
Tartaric Acid		irritant
Thioglycolic acid		very toxic, corrosive
Thionyl Chloride		corrosive
Titanium(III)chloride solution	typically 20%	corrosive
Tin(II)chloride		corrosive, toxic
Tin(IV)chloride		corrosive, toxic
Tributyl Phosphate		humful, toxic, flammable
Triethylamine		highly flammable, corrosive, humful
Uric acid		irritant
Fuming sulphuric acid	trace	highly corrosive
Sodium hydroxide, aqueous	any	corrosive, strong bases
KOH(potassium hydroxide)	any	corrosive, strong bases
Ca(OH)2(calcium hydroxide)	any	corrosive, strong bases

P.S. 1) corrosive; strongly corrosive; strong acid; strong bases; humful; very humful; flammable.
 2) irritant; toxic; combustible.



corrosive
strongly corrosive
strong acid
strong bases



toxic
humful
irritant



flammable
combustible

Regulation Abstract

Safety Storage Cabinet

Storage Container

Spill Prevention Containment & Control System



OSHA 29 CFR 1910.106

OSHA 29 CFR 1910.106(a)(19)

Flammable liquid means any liquid having a flashpoint at or below 199.4 °F (93 °C). Flammable liquids are divided into four categories as follows:

1910.106(a)(19)(i, ii, iii, iv & v)

Category 1 shall include liquids having flashpoints below 73.4 °F (23 °C) and having a boiling point at or below 95 °F (35 °C). Category 2 shall include liquids having flashpoints below 73.4 °F (23 °C) and having a boiling point above 95 °F (35 °C). Category 3 shall include liquids having flashpoints at or above 73.4 °F (23 °C) and at or below 140 °F (60 °C). When a Category 3 liquid with a flashpoint at or above 100 °F (37.8 °C) is heated for use to within 30 °F (16.7 °C) of its flashpoint, it shall be handled in accordance with the requirements for a Category 3 liquid with a flashpoint below 100 °F (37.8 °C). Category 4 shall include liquids having flashpoints above 140 °F (60 °C) and at or below 199.4 °F (93 °C). When a Category 4 flammable liquid is heated for use to within 30 °F (16.7 °C) of its flashpoint, it shall be handled in accordance with the requirements for a Category 3 liquid with a flashpoint at or above 100 °F (37.8 °C). When liquid with a flashpoint greater than 199.4 °F (93 °C) is heated for use to within 30 °F (16.7 °C) of its flashpoint, it shall be handled in accordance with the requirements for a Category 4 flammable liquid.

OSHA 29 CFR 1910.106(d)(3)

"Design, construction, and capacity of storage cabinets" -

1910.106(d)(3)(i)

"Maximum capacity." Not more than 60 gallons of Category 1, 2, or 3 flammable liquids, nor more than 120 gallons of Category 4 flammable liquids may be stored in a storage cabinet.

1910.106(d)(3)(ii)

"Fire resistance." Storage cabinets shall be designed and constructed to limit the internal temperature to not more than 325 deg. F. when subjected to a 10-minute fire test using the standard time-temperature curve as set forth in Standard Methods of Fire Tests of Building Construction and Materials, NFPA 251-1969, which is incorporated by reference as specified in Sec. 1910.6. All joints and seams shall remain tight and the door shall remain securely closed during the fire test. Cabinets shall be labeled in conspicuous lettering, "Flammable - Keep Fire Away."

1910.106(d)(3)(iii)(a)

Metal cabinets constructed in the following manner shall be deemed to be in compliance. The bottom, top, door, and sides of cabinet shall be at least No. 18 gage sheet iron and double walled with 1 1/2 - inch air space. Joints shall be riveted, welded or made tight by some equally effective means. The door shall be provided with a three-point lock, and the door sill shall be raised at least 2 inches above the bottom of the cabinet.

1910.106(d)(3)(iii)(b)

Wooden cabinets constructed in the following manner shall be deemed in compliance. The bottom, sides, and top shall be constructed of an approved grade of plywood at least 1 inch in thickness, which shall not break down or delaminate under fire conditions. All joints shall be rabbeted and shall be fastened in two directions with flathead woodscrews. When more than one door is used, there shall be a rabbeted overlap of not less than 1 inch. Hinges shall be mounted in such a manner as not to lose their holding capacity due to loosening or burning out of the screws when subjected to the fire test.

OSHA 29 CFR 1910.106 (a)(29)

Safety can shall mean an approved container,

of not more than 5 gallons capacity, having a spring-closing lid and spout cover and so designed that it will safely relieve internal pressure when subjected to fire exposure.

OSHA 29 CFR 1910.125(e)(4)(ii&iii)

Rags and other material contaminated with liquids from dipping or coating operations are placed in approved waste cans immediately after use; and waste can contents are properly disposed of at the end of each shift.

OSHA 29 CFR 1910.144(a)(1)(ii)

Danger. Safety cans or other portable containers of flammable liquids having a flash point at or below 80°F, table containers of flammable liquids (open cup tester), excluding shipping containers, shall be painted red with some additional clearly visible identification either in the form of a yellow band around the can or the name of the contents conspicuously stenciled or painted on the can in yellow. Red lights shall be provided at barricades and at temporary obstructions. Danger signs shall be painted red.

NFPA CODE 30 2012 Edition FLAMMABLE AND COMBUSTIBLE LIQUIDS CODE

9.5 Flammable Liquids Storage Cabinets.

9.5.1 The volume of Class I, Class II, and Class IIIA liquids stored in an individual storage cabinet shall not exceed 120 gal (460 L)

9.5.2 The total aggregate volume of Class I, Class II, and Class IIIA liquids in a group of storage cabinets shall not exceed the maximum allowable quantity of flammable and combustible liquids per control area based on the occupancy where the cabinets are located.

9.5.4 Storage cabinets shall not be required by this code to ventilated for fire protection purposes.

9.5.4.1 If a storage cabinet is not ventilated, the vent openings shall be sealed with the bungs supplied with the cabinet or with bungs specified by the cabinet manufacturer.

EPA 40 CFR 264.175:

Containment. (a) Container storage areas must have a containment system that is designed and operated in accordance with paragraph (b) of this section, except as otherwise provided by paragraph (c) of this section.

(b) A containment system must be designed and operated as follows:

(3) The containment system must have sufficient capacity to contain 10% of the volume of containers or the volume of the largest container, whichever is greater. Containers that do not contain free liquids need not be considered in this determination.

Spill Prevention, Control and Countermeasures (SPCC) Compliant

What is SPCC and who is regulated by the rule? SPCC is short for Spill Prevention Control and Countermeasures. The rule was developed under the authority of The Federal Water Pollution Control Act and The Clean Water Act, and is designed to prevent oil pollution in US waterways. The SPCC Rule outlines the requirement of owners and operators of on shore facilities and offshore facilities to prepare and implement a Spill Prevention Control and Countermeasures plan.

Application to spill control products. The SPCC Rule outlines the requirement of an owner and operator to demonstrate in their SPCC plans considerations for secondary containment solutions for containers 55 gallons and larger. Each secondary containment shall be as follows:

1) To hold the entire capacity of the largest container.

2) To have sufficient freeboard to hold precipitation.

Notes:

1) Freeboard: the vertical distance to the lowest point of over flow.

2) Adequate freeboard needs to be determined by the owner, or the operator or their engineer as outlined in their plan.

3) Pallets that are sheltered do not require freeboard to hold precipitation. This would be implied under "good engineering practices."

ANSI Z358.1-2014 Standards for Emergency Eyewash and Shower Equipment:

(1) Specifying the minimum performance and operation requirements of emergency eyewash and shower equipment;

(2) Providing the detailed guidance on product design, installation, certification, maintenance and training.

SCS Safety Containment Systems		Page
WA810040	Flammable Cabinets(4 Gal)	7
WA810041	Self-closed Flammable Cabinets(4 Gal)	7
WA810100	Flammable Cabinets(10 Gal)	7
WA810120	Flammable Cabinets(12 Gal)	7
WA810121	Self-closed Flammable Cabinets(12 Gal)	7
WA3810120	EX Piggyback Flammable Cabinets(12 Gal)	7
WA810170	Wall Mounted Flammable Cabinets(17Gal)	7
WA3810170	EX Piggyback Flammable Cabinets(17Gal)	7
WA0810190	Undercounter Flammable Cabinets(19 Gal)	7
WA810220	Flammable Cabinets(22 Gal)	7
WA810221	Self-closed Flammable Cabinets (22 Gal)	7
WA0810230	Undercounter Flammable Cabinets(23 Gal)	7
WA810300	Flammable Cabinets(30 Gal)	7
WA810301	Self-closed Flammable Cabinets(30 Gal)	7
WA810300C	Flammable Cabinets(30 Gal)	7
WA810450	Flammable Cabinets(45 Gal)	7
WA810451	Self-closed Flammable Cabinets(45 Gal)	7
WA810540	Flammable Cabinets(54 Gal)	7
WA810541	Self-closed Flammable Cabinets(54 Gal)	7
WA810600	Flammable Cabinets(60 Gal)	7
WA810601	Self-closed Flammable Cabinets(60 Gal)	7
WA810860	Flammable Cabinets(90 Gal)	7
WA810861	Self-closed Flammable Cabinets(90 Gal)	7
WA810122	GA Password lock Flammable Cabinets(12 Gal)	7
WA810452	GA Password lock Flammable Cabinets(45 Gal)	7
WA810550	Drum Storage Cabinet(55 Gal)	8
WA811100	Drum Storage Cabinet(110 Gal)	8
WA810115	Drum Storage Cabinet(115 Gal)	8
WA810040R	Combustible Cabinets(4 Gal)	8
WA810120R	Combustible Cabinets(12 Gal)	8
WA810300R	Combustible Cabinets(30 Gal)	8
WA810450R	Combustible Cabinets(45 Gal)	8
WA810600R	Combustible Cabinets(60 Gal)	8
WA810860R	Combustible Cabinets(90 Gal)	8
WA810040B	Corrosive Cabinets(4 Gal)	9
WA810120B	Corrosive Cabinets(12 Gal)	9
WA810220B	Corrosive Cabinets(22 Gal)	9
WA810300B	Corrosive Cabinets(30 Gal)	9
WA810450B	Corrosive Cabinets(45 Gal)	9
WA810600B	Corrosive Cabinets(60 Gal)	9
WA810860B	Corrosive Cabinets(90 Gal)	9
WA810120W	Toxic Cabinets(12 Gal)	9
WA810450W	Toxic Cabinets(45 Gal)	9
WA810122W	Toxic Cabinets(12 Gal)	9
WA810452W	Toxic Cabinets(45 Gal)	9
WA810120G	Pesticides Cabinets(12 Gal)	10
WA810450G	Pesticides Cabinets(45 Gal)	10
WA810303	Waste Liquid Storage Cabinets(30 Gal)	10
WA810453	Waste Liquid Storage Cabinets(45 Gal)	10
WA920450	Emergency Equipment Cabinet	11
WA930450	Emergency Equipment Cabinet	11
WA920450Y	Emergency Equipment Cabinet	11
WA930450Y	Emergency Equipment Cabinet	11
WA710204	Gas Cylinder Storage Cages	11
WA710208	Gas Cylinder Storage Cages	11
WA710216	Gas Cylinder Storage Cages	11
WA710309	Gas Cylinder Storage Cages	11
WA710318	Gas Cylinder Storage Cages	11
WA710589	Gas Cylinder Storage Cages	11
SE830230	Safety Storage Cabinet	12
SE830450	Safety Storage Cabinet	12
SE490190	Safety Storage Cabinet	12
SE490230	Safety Storage Cabinet	12
SE490300	Safety Storage Cabinet	12
SE490450	Safety Storage Cabinet	12
WA510024	Outdoor Safety Cabinet	13
WA510025	Outdoor Safety Cabinet	13
WA940101	Mobile Safety Storage Box	13
WA940102	Mobile Safety Storage Box	13
WA8109400	Waste Recycling Cabinet	14
LSEF001118	Explosion-proof Refrigerator	14
LSEF002310	Explosion-proof Refrigerator	14
ACP80001	Polyethylene Corrosive Cabinet(4 Gal)	15
ACP80002	Polyethylene Corrosive Cabinet(22 Gal)	15
ACP810004	Corrosive Substance Storage Cabinets(4 Gal)	16
ACP810012	Corrosive Substance Storage Cabinets(12 Gal)	16
ACP810024	Corrosive Substance Storage Cabinets(24 Gal)	16
ACP810030	Corrosive Substance Storage Cabinets(30 Gal)	16
ACP810048	Corrosive Substance Storage Cabinets(48 Gal)	16
ACP810048T	Corrosive Substance Storage Cabinets(48 Gal)	16
ACP810045A	PP Medicine Storage Cabinets	16
ACP810045B	PP Medicine Storage Cabinets	16
SCAN001R	Safety Cans(2.5 Gal)(Red)(TYPE I)	17
SCAN001Y	Safety Cans(2.5 Gal)(Yellow)(TYPE I)	17
SCAN002R	Safety Cans(5 Gal)(Red)(TYPE I)	17
SCAN002Y	Safety Cans(5 Gal)(Yellow)(TYPE I)	17
SCAN003R	Safety Cans(2.5 Gal)(Red)(TYPE II)	17
SCAN003Y	Safety Cans(2.5 Gal)(Yellow)(TYPE II)	17
SCAN004R	Safety Cans(5 Gal)(Red)(TYPE II)	17
SCAN004Y	Safety Cans(5 Gal)(Yellow)(TYPE II)	17
WA8109100	Oily Waste Cans(6 Gal)(Red)	17

SCS Safety Containment Systems		Page
WA8109100Y	Oily Waste Cans(6 Gal)(Yellow)	17
WA8109300	Oily Waste Cans(10 Gal)(Red)	17
WA8109300Y	Oily Waste Cans(10 Gal)(Yellow)	17
WA8109500	Oily Waste Cans(14 Gal)(Red)	17
WA8109500Y	Oily Waste Cans(14 Gal)(Yellow)	17
WA8109700	Oily Waste Cans(21 Gal)(Red)	17
WA8109700Y	Oily Waste Cans(21 Gal)(Yellow)	17
WA8109200	Biohazard Waste Can(6 Gal)(Red)	18
WA8109200Y	Biohazard Waste Can(6 Gal)(Yellow)	18
WA8109600	Biohazard Waste Can(14 Gal)(Red)	18
WA8109600Y	Biohazard Waste Can(14 Gal)(Yellow)	18
CBR8101	Cigarette Butts Receptacle(Red)	18
CBR8102	Cigarette Butts Receptacle(Gray)	18
WAL040	Galvanized Steel Shelf	19
WAL010	Galvanized Steel Shelf	19
WAL012	Galvanized Steel Shelf	19
WAL019	Galvanized Steel Shelf	19
WAL022	Galvanized Steel Shelf	19
WAL03045	Galvanized Steel Shelf	19
WAL054	Galvanized Steel Shelf	19
WAL060	Galvanized Steel Shelf	19
WAL090	Galvanized Steel Shelf	19
WAL110	Galvanized Steel Shelf	19
WAL115L	Galvanized Steel Shelf	19
WAL115R	Galvanized Steel Shelf	19
WAB002	VOC Filter Device	19
WADR001	Oily Drum Safety Cabinets/Roller	19
WAR001	Oily Drum Safety Cabinets Ramp	19
WA001	Antistatic Device	19
WA002	Antistatic Device	19
WAB001	MSDS Document Box	19
SCL001	Metal Locks	19
SCL002	Polyethylene locks(Short)	19
SCL003	Polyethylene locks(long)	19
WA005	Cabinet Ventilation Parts	19
WA006	PP Cabinet Ventilation Parts	19
ACPL001	PE Shelf	19
ACPL002	PE Shelf	19
ACPL004	PE Shelf	19
ACPL012	PE Shelf	19
ACPL024	PE Shelf	19
ACPL048	PE Shelf	19
ACPL030	PE Shelf	19
WAS0014	Oily Waste Can Dolly	19
WAS0021	Oily Waste Can Dolly	19
WAW005	Plastic Barrel(5L)	19
WAW020	Plastic Barrel(20L)	19
WAW030	Plastic Barrel(30L)	19
WAT004	4 gallons cabinet PE plastic tray	19
WAT01222	12/22 gallons cabinet PE plastic tray	19
WAT03045	30/45 gallons cabinet PE plastic tray	19
WAT060	60 gallons cabinet PE plastic tray	19

SPCC Spill Prevention, Containment & Control		Page
SPP401	Poly Spill Deck(Single Drum)	23
SPP101	Poly Spill Deck(2 Drum)	23
SPP103	Poly Spill Deck(4 Drum)	23
SPP102	Poly Spill Pallet(2 Drum)	23
SPP102H	Poly Spill Pallet(2 Drum)	23
SPP104-2	Poly Spill Pallet(4 Drum)	23
SPL001	Lab Spill Containment Pallet	23
SPP101-2	Modular PE Spill Decks	24
SPP105	IBC Poly Spill Pallet	25
SPM202	Steel Spill Pallet(2 Drum)	25
SPM204	Steel Spill Pallet(4 Drum)	25
SPM222	Mobile Steel Spill Pallet(with cart)	25
SPM304	Steel Spill Pallet(3 Drum)	25
SPM112	IBC steel spill pallet	25
SPP001	Poly Spill Pallet Ramp	26
SPP012	Poly Spill Deck Ramp	26
SPP013	Two-drum Poly Spill Deck Cart	26
SPP021	Waterproof Tape	26
OP0001W	Oil-Only Absorbent Pad	28
CP0001Y	Hazmat Absorbent Pad	28
UP0001G	Universal Absorbent Pad	28
OP0002W	Oil-Only Absorbent Pad	28
CP0002Y	Hazmat Absorbent Pad	28
UP0002G	Universal Absorbent Pad	28
OM0001W	Oil-Only Poly-Back Absorbent Mat	28
CM0001Y	Hazmat Poly-Back Absorbent Mat	28
UM0001G	Universal Poly-Back Absorbent Mat	28
OS0001W	Oil-Only Absorbent Sock	28
CS0001Y	Hazmat Absorbent Sock	28
US0001G	Universal Absorbent Sock	28
OB0001W	Oil-Only Absorbent Boom	28
CB0001Y	Hazmat Absorbent Boom	28
UB0001G	Universal Absorbent Boom	28
DOP001	Oil-Only Drum Mat	28
DCP001	Hazmat Drum Mat	28
DUP001	Universal Drum Mat	28

SPCC Spill Prevention, Containment & Control		Page
SOP001	Oil-Only Absorbent Pillow	28
SCP001	Hazmat Absorbent Pillow	28
SUP001	Universal Absorbent Pillow	28
SOR001	Oil-Only Absorbent Roll	28
SCR001	Hazmat Absorbent Roll	28
SUR001	Universal Absorbent Roll	28
SOR002	Oil-Only Absorbent Roll	28
SCR002	Hazmat Absorbent Roll	28
SUR002	Universal Absorbent Roll	28
SUR003	Universal Absorbent Roll	28
SUR004	Heavy universal absorbent mat	29
SUR005	Heavy universal absorbent mat	29
SUR006	Heavy absorbent mat roll	29
SUR007	Heavy absorbent mat roll (backgum)	29
SWF101	CLEANROOM WIPES(White)	30
SWR201Y	INDUSTRIAL WIPING(Yellow)	30
SWF201Y	INDUSTRIAL WIPING(Yellow)	30
SCR301B	INDUSTRIAL WIPING(Blue)	30
SCF301B	INDUSTRIAL WIPING(Blue)	30
SCR321W	INDUSTRIAL WIPING(White)	30
DUP002	Universal Absorbent Drip Pan	31
SYD950	Overpack Salvage Drum(95Gal)	32
SYD200	Overpack Salvage Drum(20Gal)	32
SYD001	Steel Dolly for Overpack Salvage Drum	32
SYK201	20Gal-Drum Overpack Spill Kit(Oil Only)	32
SYK202	20Gal-Drum Overpack Spill Kit(Chemical Only)	32
SYK200	20Gal-Drum Overpack Spill Kit(Universal)	32
SYK203	20Gal-Drum Overpack Wiping Adsorption Spill Kit (Universal)	32
SYK952	95Gal-Drum Overpack Spill Kit(Oil Only)	33
SYK951	95Gal-Drum Overpack Spill Kit(Chemical Only)	33
SYK950	95Gal-Drum Overpack Spill Kit(Universal)	33
SYK652	65Gal-Drum Overpack Spill Kit(Oil Only)	33
SYK651	65Gal-Drum Overpack Spill Kit(Chemical Only)	33
SYK650	65Gal-Drum Overpack Spill Kit(Universal)	33
SYD650	65-Gallon Wheeled Poly-Overpack Salvage Drum	33
SKIT002W	Mobile Spill Kit(Oil Only)	34
SKIT002Y	Mobile Spill Kit(Chemical Only)	34
SKIT002G	Mobile Spill Kit(Universal)	34
SKIT001W	Portable Spill Kit(Oil Only)	34
SKIT001Y	Portable Spill Kit(Chemical Only)	34
SKIT001G	Portable Spill Kit(Universal)	34
SKS001W	Spill Kits Refills(Oil Only)	34
SKS001Y	Spill Kits Refills(Chemical Only)	34
SKS001G	Spill Kits Refills(Universal)	34
SYK562	Spill Kits in Cart(Oil Only)	35
SYK561	Spill Kits in Cart(Chemical Only)	35
SYK560	Spill Kits in Cart(Universal)	35
WA940640	High-quality galvanized steel	35
SYB200	Polyethylene Disposal Bags (Medium)	35
SYB950	Polyethylene Disposal Bags (Large)	35
FTB001	PVC Float-Type Spill Containment Boom</	

Please contact the nearest distributor

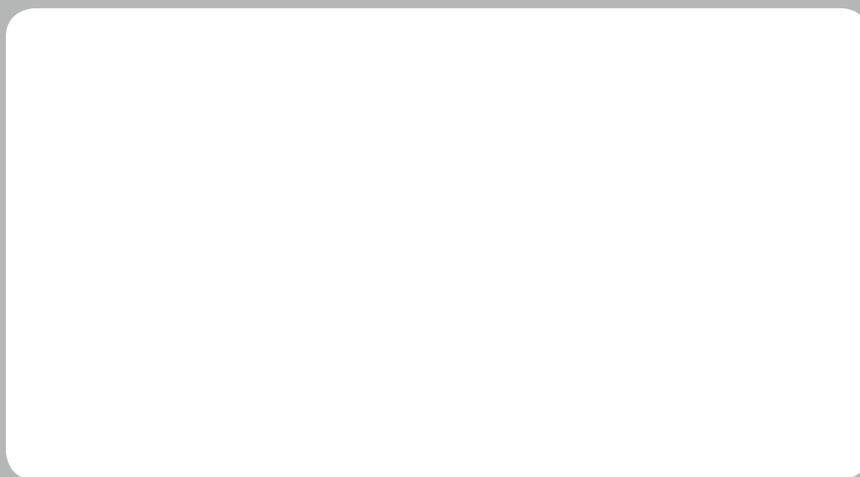

SYSBEL IS SAFETY



Customers are the core of **SYSBEL**, as well as the definers of our service and product quality. **SYSBEL** attaches great importance to customers' feedback and experience. Customers' satisfaction is crucial to us, because if we fail, others will make it.

